

# Table of Contents

Introduction .....	2
Need for Circuit Protection .....	4
Types of Overcurrent Protective Devices .....	8
Circuit Breaker Design .....	11
Types of Circuit Breakers .....	23
Circuit Breaker Ratings .....	27
Time-Current Curves .....	29
Selective Coordination .....	32
Series-Connected Systems .....	34
Siemens Circuit Breakers .....	37
Residential Circuit Breakers .....	38
Panelboard Circuit Breakers .....	46
General Purpose Thermal-Magnetic Circuit Breakers .....	49
Solid-State Trip Unit Circuit Breakers .....	56
Internal Accessories .....	62
External Accessories .....	65
VL Circuit Breakers .....	71
WL Circuit Breakers .....	79
Review Answers .....	84
Final Exam .....	85
quickSTEP Online Courses .....	88

# Introduction

Welcome to another course in the STEP series, **Siemens Technical Education Program**, designed to prepare our distributors to sell Siemens Energy & Automation products more effectively. This course covers **Basics of Circuit Breakers** and related products.

Upon completion of **Basics of Circuit Breakers** you will be able to:

- Explain the need for circuit protection
- Identify various types of overcurrent protective devices
- Explain the basic electro-mechanical operation of a circuit breaker
- Identify various types of Siemens circuit breakers
- Identify circuit protection ratings for various types of Siemens circuit breakers
- Describe time-current characteristics on a time-current curve
- Explain the benefits and function of circuit breaker coordination
- Identify internal and external circuit breaker accessories

This knowledge will help you better understand customer applications. In addition, you will be better able to describe products to customers and determine important differences between products. You should complete **Basics of Electricity** before attempting **Basics of Circuit Breakers**. An understanding of many of the concepts covered in **Basics of Electricity** is required for **Basics of Circuit Breakers**.

If you are an employee of a Siemens Energy & Automation authorized distributor, fill out the final exam tear-out card and mail in the card. We will mail you a certificate of completion if you score a passing grade. Good luck with your efforts.

Siemens is a trademark of Siemens AG. Product names mentioned may be trademarks or registered trademarks of their respective companies. Specifications subject to change without notice.

*National Electrical Code*® and *NEC*® are registered trademarks of the National Fire Protection Association, Quincy, MA 02169-7471.

Portions of the *National Electrical Code*® are reprinted with permission from NFPA 70®, *National Electrical Code*® Copyright © 2008, National Fire Protection Association, Quincy, MA 02169. This reprinted material is not the complete and official position of the National Fire Protection Association on the referenced subject, which is represented only by the standard in its entirety.

NEMA® is a registered trademark and service mark of the National Electrical Manufacturers Association, Rosslyn, VA 22209.

Underwriters Laboratories Inc.® and UL® are registered trademarks of Underwriters Laboratories Inc., Northbrook, IL 60062-2096.

Other trademarks are the property of their respective owners.

# Need for Circuit Protection

## Current and Temperature

Current flow in a conductor always generates heat. The greater the current flow, the hotter the conductor. Excess heat is damaging to electrical components and conductor insulation. For that reason, conductors have a rated continuous current carrying capacity or **ampacity**. Overcurrent protection devices, such as **circuit breakers**, are used to protect conductors from excessive current flow. These protective devices are designed to keep the flow of current in a circuit at a safe level to prevent the circuit conductors from overheating.

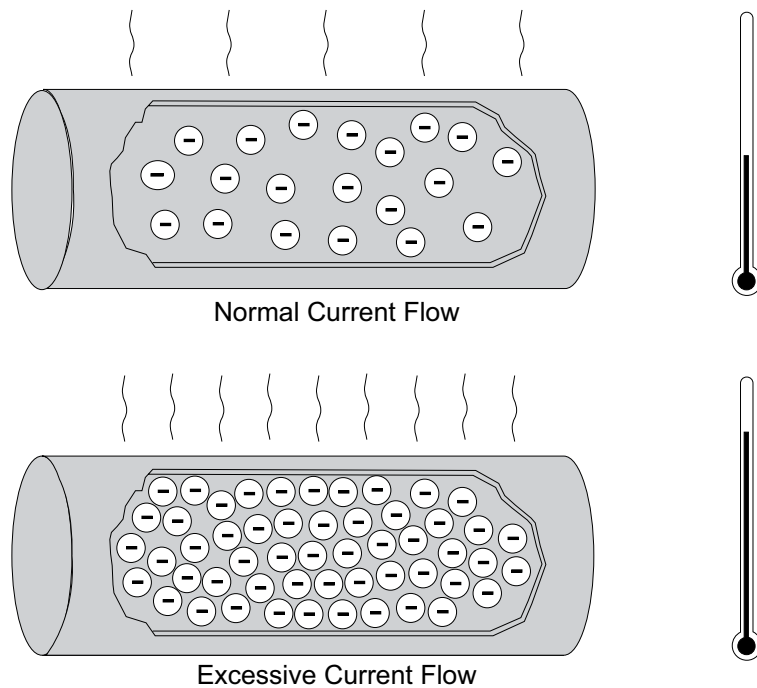

Excessive current is referred to as **overcurrent**. The *National Electrical Code*® (*NEC*®) defines overcurrent as *any current in excess of the rated current of equipment or the ampacity of a conductor. It may result from overload, short circuit, or ground fault* (Article 100-Definitions).

*Reprinted with permission from NFPA 70® , National Electrical Code®, Copyright © 2008, National Fire Protection Association, Quincy, MA 02169. This reprinted material is not the complete and official position of the National Fire Protection Association on the referenced subject, which is represented only by the standard in its entirety.*

## Overloads

An **overload** occurs when too many devices are operated on a single circuit, or a piece of electrical equipment is made to work harder than it is designed for. For example, a motor rated for 10 amps may draw 20, 30, or more amps in an overload condition. In the following illustration, a package has become jammed on a conveyor, causing the motor to work harder and draw more current. Because the motor is drawing more current, it heats up. Damage will occur to the motor in a short time if the problem is not corrected or the circuit is shut down by the overcurrent protector.

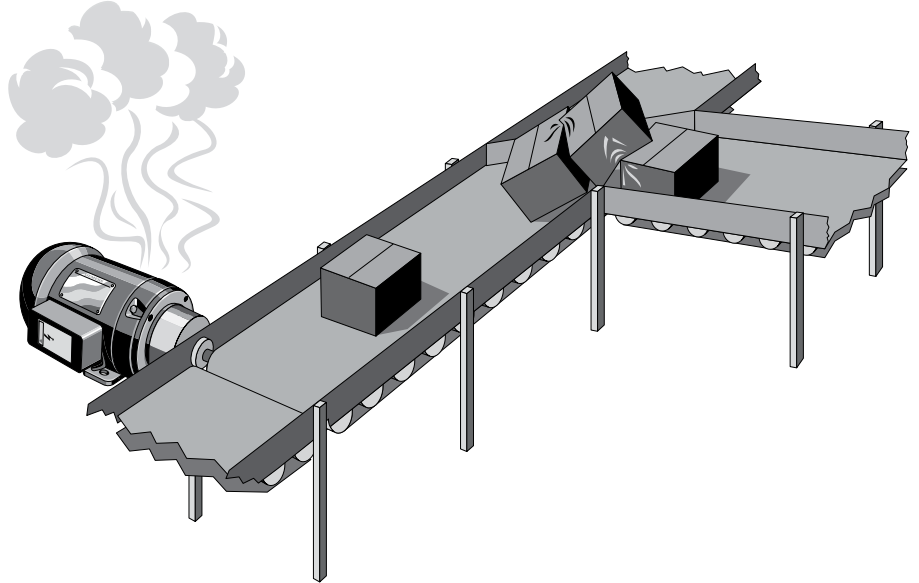

## Conductor Insulation

Motors, of course, are not the only devices that require circuit protection for an overload condition. Every circuit requires some form of protection against overcurrent. Heat is one of the major causes of insulation failure of any electrical component. High levels of heat can cause the insulation to breakdown and flake off, exposing conductors.

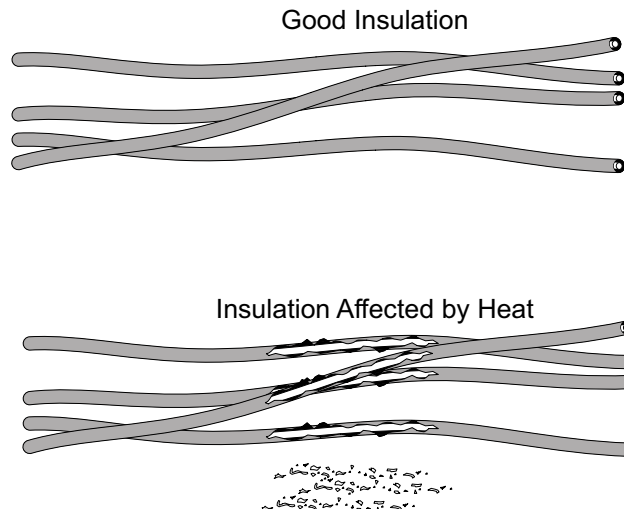

## Short Circuits

When two bare conductors touch, either phase to phase or phase to ground, a **short circuit** occurs. When a short circuit occurs, resistance drops to almost zero. Short circuit current can be thousands of times higher than normal operating current.

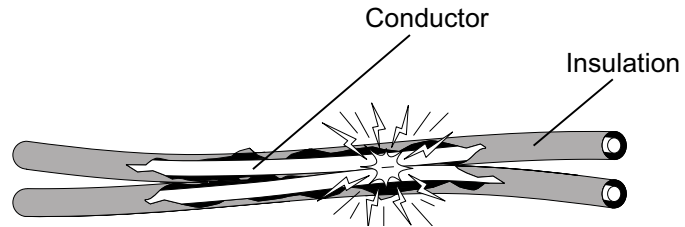

**Ohm's Law** demonstrates the relationship of current, voltage, and resistance. For example, a 240 volt motor with  $24 \Omega$  of resistance would normally draw 10 amps of current.

$$I = \frac{E}{R}$$
$$I = \frac{240 \text{ V}}{24 \Omega}$$
$$I = 10 \text{ A}$$

When a short circuit develops, resistance drops. If resistance drops to 24 milliohms, current will be 10,000 amps.

$$I = \frac{240 \text{ V}}{0.024 \Omega}$$
$$I = 10,000 \text{ A}$$

The heat generated by this current will cause extensive damage to connected equipment and conductors. This dangerous current must be interrupted immediately when a short circuit occurs.

## Ampacities of Insulated Conductors

Table 310.16 of the *NEC*<sup>®</sup> provides the maximum current for a given conductor. For example, a #8 American wire guage (AWG) copper conductor with Type THW insulation is rated for 50 amps at 75° C. To avoid overloads and prevent insulation damage, it is necessary to keep the current from exceeding the conductor's continuous current rating.

**Table 310.16 Allowable Ampacities of Insulated Conductors Rated 0 Through 2000 Volts. 60°C Through 90°C (140°F Through 194°F). Not More Than Three Current-Carrying Conductors in Raceway, Cable, or Earth (Directly Buried), Based on Ambient Temperature of 30°C (86°F)**

Size AWG or kcmil	Temperature Rating of Conductor (See Table 310.13)						Size AWG or kcmil
	60°C (140°F)	75°C (167°F)	90°C (194°F)	60°C (140°F)	75°C (167°F)	90°C (194°F)	
	Types TW, UF	Types RHW, THHW, THW, THWN, XHHW, USE, ZW	Types TBS, SA, SIS, FEP, FEPB, MI, RHH, RHW-2, THHN, THHW, THW-2, THWN-2, USE,2, XHH, XHHW, XHHW-2, ZW-2	Types TW, UF	Types RHW, THHW, THW, THWN, XHHW, USE, ZW	Types TBS, SA, SIS, THHN, THHW, THW-2, THWN-2, RHH, RHW-2, USE- 2, XHH, XHHW, XHHW-2, ZW-2	
	COPPER			ALUMINUM OR COPPER-CLAD ALUMINUM			
18	-	-	14	-	-	-	-
16	-	-	18	-	-	-	-
14*	20	20	25	-	-	-	-
12*	25	25	30	20	20	25	12*
10*	30	35	40	25	30	35	10*
8	40	50	55	30	40	45	8
6	55	65	75	40	50	60	6
4	70	85	95	55	65	75	4
3	85	100	110	65	75	85	3
2	95	115	130	75	90	100	2
1	110	130	150	85	100	115	1
1/0	125	150	170	100	120	135	1/0
2/0	145	175	195	115	135	150	2/0
3/0	165	200	225	130	155	175	3/0
4/0	195	230	260	150	180	205	4/0
250	215	255	290	170	205	230	250
300	240	285	320	190	230	255	300
350	260	310	350	210	250	280	350
400	280	335	380	225	270	305	400
500	320	380	430	260	310	350	500
600	355	420	475	285	340	385	600
700	385	460	520	310	375	420	700
750	400	475	535	320	385	435	750
800	410	490	555	330	395	450	800
900	435	520	585	355	425	480	900
1000	455	545	615	375	445	500	1000
1250	495	590	665	405	485	545	1250
1500	520	625	705	435	520	585	1500
1750	545	650	735	455	545	615	1750
2000	560	665	750	470	560	630	2000

If the raceway contains more than three conductors or the ambient temperature is greater than 30°C (86°F) the values shown in Table 310.16 must be reduced using derating values provided by *NEC*<sup>®</sup> (not shown here).

*Reprinted with permission from NFPA 70<sup>®</sup>, National Electrical Code<sup>®</sup>, Copyright © 2008, National Fire Protection Association, Quincy, MA 02169. This reprinted material is not the complete and official position of the National Fire Protection Association on the referenced subject, which is represented only by the standard in its entirety.*

# Types of Overcurrent Protective Devices

Circuit protection would be unnecessary if overloads and short circuits could be eliminated. Unfortunately, overloads and short circuits do occur. To protect a circuit against these currents, a protective device must determine when a fault condition develops and automatically disconnect the electrical equipment from the voltage source. An overcurrent protection device must be able to recognize the difference between overcurrents and short circuits and respond in the proper way. Slight overcurrents can be allowed to continue for some period of time, but as the current magnitude increases, the protection device must open faster. Short circuits must be interrupted instantaneously. Several devices are available to accomplish this.

## Fuse

A **fuse** is a one-shot device. The heat produced by overcurrent causes the current carrying element to melt open, disconnecting the load from the source voltage.

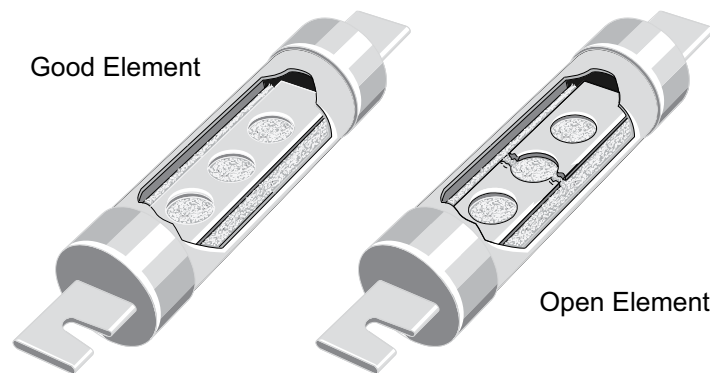

## Nontime-Delay Fuse

Fuses without time delay provide excellent short circuit protection. When an overcurrent situation occurs, heat builds up rapidly in the fuse. Fuses without time delay usually hold 500% of their rating for approximately one-fourth second, after which the current carrying element melts. This means that these fuses cannot be used in motor circuits which often have inrush currents of greater than 500%.

## Time-Delay Fuses

**Time-delay fuses** provide overload and short circuit protection. Time-delay fuses usually allow five times the rated current for up to ten seconds to allow motors to start.



## Circuit Breaker

The *National Electrical Code*® defines a circuit breaker as a device designed to open and close a circuit by nonautomatic means and to open the circuit automatically on a predetermined overcurrent without damage to itself when properly applied within its rating. (Article 100-Definitions)

Circuit breakers provide a manual means of energizing and de-energizing a circuit. In addition, circuit breakers provide automatic overcurrent protection of a circuit. A circuit breaker allows a circuit to be reactivated quickly after a short circuit or overload is cleared. Unlike fuses which must be replaced when they open, a simple flip of the breaker's operating handle restores the circuit.

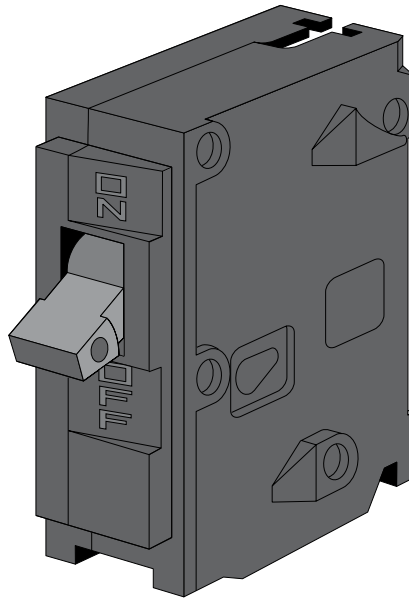

All circuit breakers perform the following functions:

- **SENSE** when an overcurrent occurs.
- **MEASURE** the amount of overcurrent.
- **ACT** by tripping the circuit breaker in a time frame necessary to prevent damage to itself and the associated load cables.

*Reprinted with permission from NFPA 70®, National Electrical Code®, Copyright © 2008, National Fire Protection Association, Quincy, MA 02169. This reprinted material is not the complete and official position of the National Fire Protection Association on the referenced subject, which is represented only by the standard in its entirety.*

## Circuit Breaker Operation

In the following illustration, an AC motor is connected through a circuit breaker to a voltage source. When the circuit breaker is closed, a complete path for current exists between the voltage source and the motor allowing the motor to run. Opening the circuit breaker breaks the path of current flow and the motor stops. The circuit breaker will open automatically during a fault, or can be manually opened. After the fault has been cleared, the breaker can be closed allowing the motor to operate.

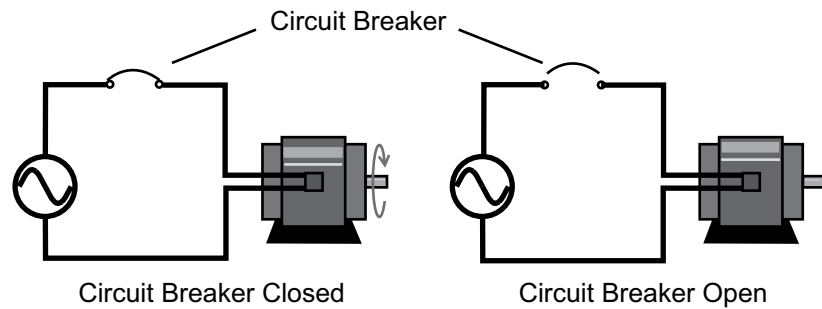

**Note:** Article 240 in the *National Electrical Code*<sup>®</sup> covers overcurrent protection. You are encouraged to become familiar with this material.

## Review 1

1. With an increase in current, heat will
  - a. increase
  - b. decrease
  - c. remain the same
2. Three causes of overcurrent are \_\_\_\_\_ , \_\_\_\_\_ , and ground faults.
3. A \_\_\_\_\_ occurs when two bare conductors, phase to phase or phase to ground, touch.
4. An \_\_\_\_\_ occurs when too many devices are operated on a single circuit or electrical equipment is required to work harder than it is rated.
5. The three functions of a circuit breaker are to \_\_\_\_\_ , \_\_\_\_\_ , and \_\_\_\_\_ .

# Circuit Breaker Design

The following section presents some basics of circuit breaker design. Variations to these design principles will be presented later in the course. Circuit breakers are constructed in five major components:

- Frame (Molded Case)
- Contacts
- Arc Chute Assembly
- Operating Mechanism
- Trip Unit

## Frame

The **frame** provides an insulated housing to mount the circuit breaker components. The construction material is usually a thermal set plastic such as glass-polymer. The construction material can be a factor in determining the interruption rating of the circuit breaker. Frame ratings indicate several pieces of important information such as; maximum voltage, maximum ampere rating, interrupting rating, and physical size.

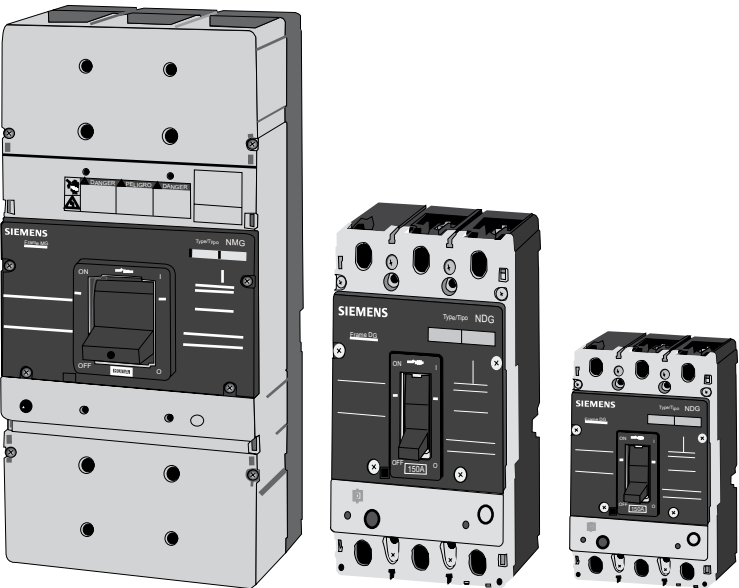

Three Circuit Breaker Frame Sizes

## Straight-Through Contacts

The current flowing in a circuit controlled by a circuit breaker flows through the circuit breaker's contacts. When a circuit breaker is turned off or is tripped by a fault current, the circuit breaker interrupts the flow of current by separating its contacts.

Many circuit breakers use a straight-through contact arrangement, so called because the current flowing in one contact arm continues in a straight line through the other contact arm.

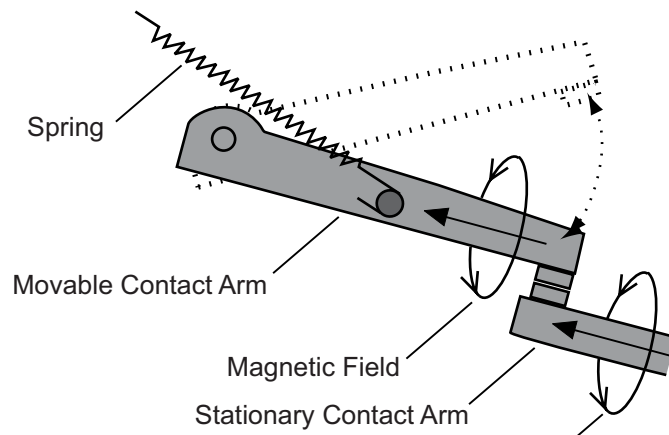

## Blow-Apart Contacts

As an improvement over the straight-through contact design, Siemens developed the **blow-apart contact design** now commonly used by circuit breakers with higher interrupting ratings. With this design, the two contact arms are positioned parallel to each other as shown in the following illustration. As current flows through the contact arms, magnetic fields are set up around each arm. Because the current flow in one arm is opposite in direction to the current flow in the other arm, the two magnetic fields oppose each other. Under normal conditions, the magnetic fields are not strong enough to force the contacts apart.

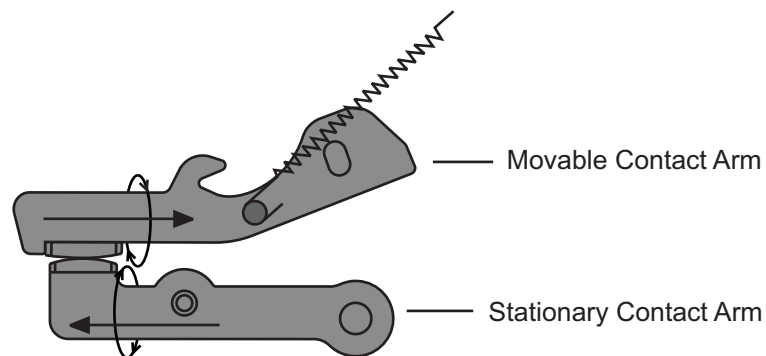

When a fault develops, current increases rapidly causing the strength of the magnetic fields surrounding the contacts to increase as well. The increased strength of the opposing magnetic fields helps to open the contacts faster by forcing them apart.

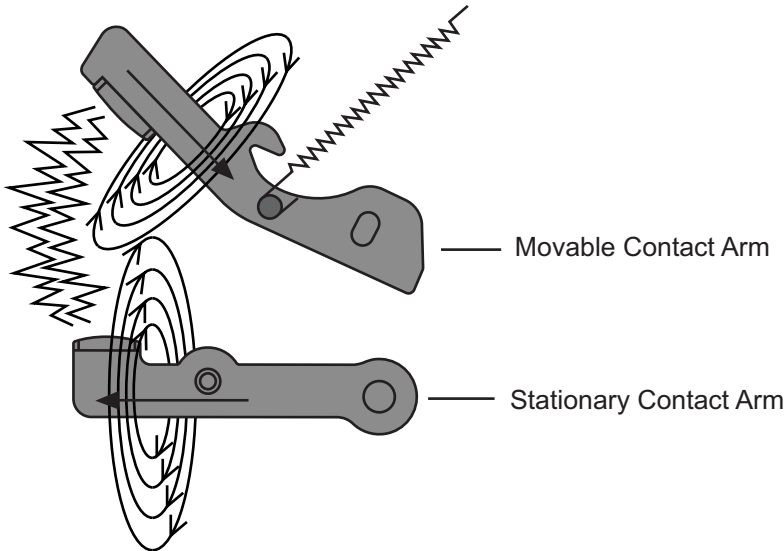

By reducing the time required to open circuit breaker contacts in the event of a fault condition, the blow-apart contact design exposes the electrical equipment protected by the circuit breaker to less damaging heat.

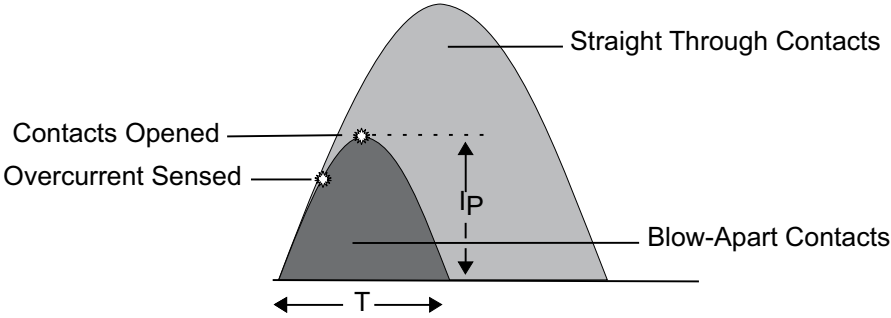

**Arc Chute Assembly**

As the contacts open a live circuit, current continues to flow for a short time by jumping the air space between the contacts in the form of an arc. When the contacts open far enough, the arc is extinguished and the current flow stops.

Minimizing the arc is important for two reasons. First, the arc can damage the contacts. In addition, the arc ionizes gases inside the molded case. If the arc isn't extinguished quickly the pressure from the ionized gases could cause the molded case to rupture.

Circuit breakers commonly use an **arc chute assembly** to quench the arc. This assembly is made up of several "U" shaped steel plates that surround the contacts. As the arc is developed, it is drawn into the arc chute where it is divided into smaller arcs, which are extinguished faster.

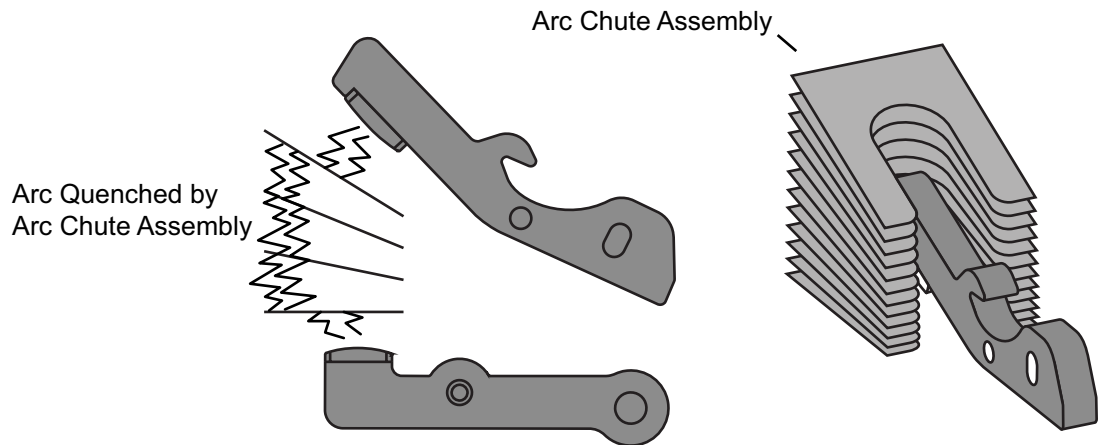

## Operating Handle

As previously stated, a circuit breaker must provide a manual means for energizing and de-energizing a circuit and must be capable of being reset after a fault condition has been cleared. These capabilities are typically provided through use of an **operating handle**.

Molded case circuit breakers (MCCBs) are trip free, meaning that they cannot be prevented from tripping by holding or blocking the operating handle in the "ON" position. There are three positions of the operating handle: "ON" (contacts closed), "OFF" (contacts open), and "TRIPPED" (mechanism in tripped position, contacts open). The circuit breaker is reset after a trip by moving the handle to the "OFF" position and then to the "ON" position.

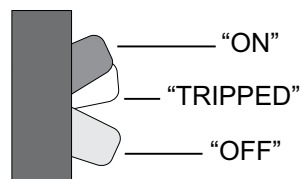

## Operating Mechanism

The operating handle is connected to the moveable contact arm through an **operating mechanism**. Siemens molded case circuit breakers use an over-center toggle mechanism that is a quick-make and quick-break design. In the following illustration, the operating handle is moved from the "OFF" to the "ON" position. In this process a spring begins to apply tension to the mechanism. When the handle is directly over the center, the tension in the spring is strong enough to snap the contacts closed. This means that the speed of the contact closing and opening is independent of how fast the handle is operated.

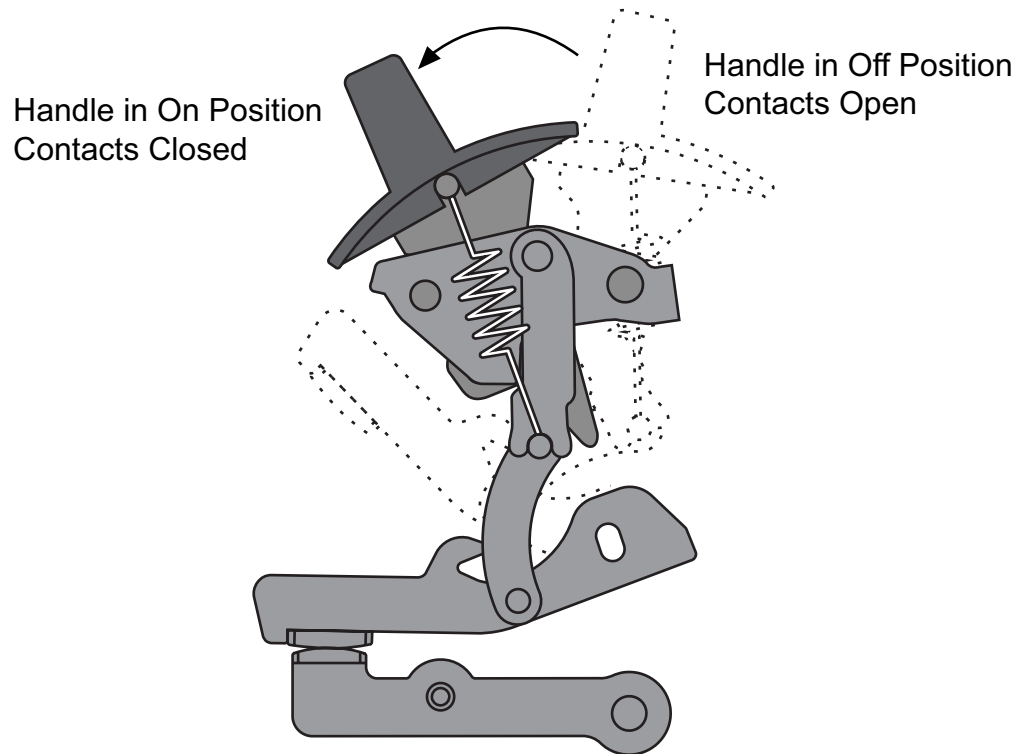

The contacts are opened by moving the operating handle from the "ON" to the "OFF" position. In this process a spring begins to apply tension to the mechanism. When the handle is directly over the center, the tension in the spring is strong enough to snap the contacts open. As in closing the circuit breaker contacts, contact opening speed is independent of how fast the handle is operated.

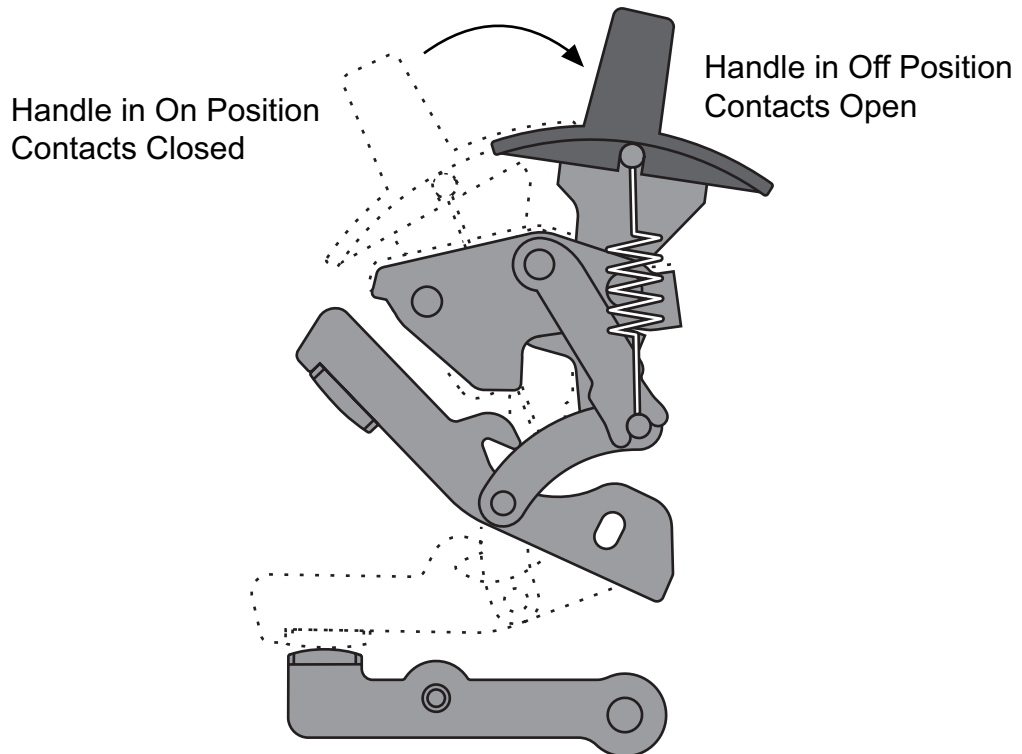

## Trip Unit

In addition to providing a means to open and close its contacts manually, a circuit breaker must automatically open its contacts when an overcurrent condition is sensed. The **trip unit** is the part of the circuit breaker that determines when the contacts will open automatically.

In a thermal-magnetic circuit breaker, the trip unit includes elements designed to sense the heat resulting from an overload condition and the high current resulting from a short circuit. In addition, some thermal-magnetic circuit breakers incorporate a "PUSH TO TRIP" button.



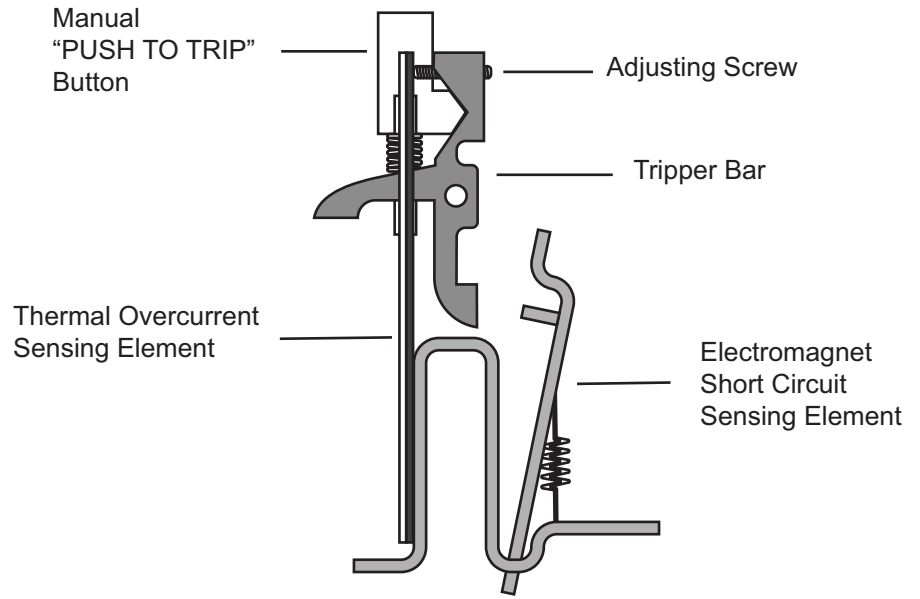

Thermal-Magnetic Trip Unit

### Trip Mechanism

The trip unit includes a **trip mechanism** that is held in place by the tripper bar. As long as the tripper bar holds the trip mechanism, the mechanism remains firmly locked in place.

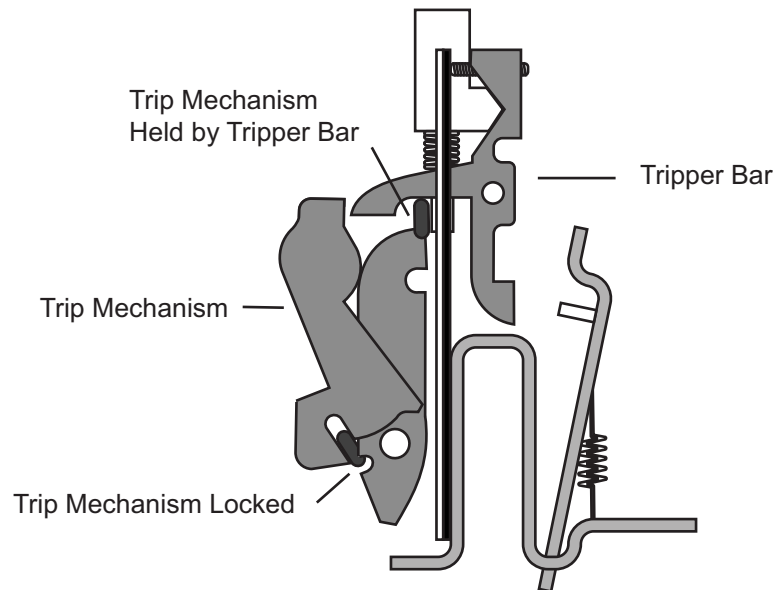

Trip Unit with Trip Mechanism

The operating mechanism is held in the "ON" position by the trip mechanism. When a trip is activated, the trip mechanism releases the operating mechanism, which opens the contacts.

Note: the drawings in this section show an AC power source; however, a DC source could also be used.

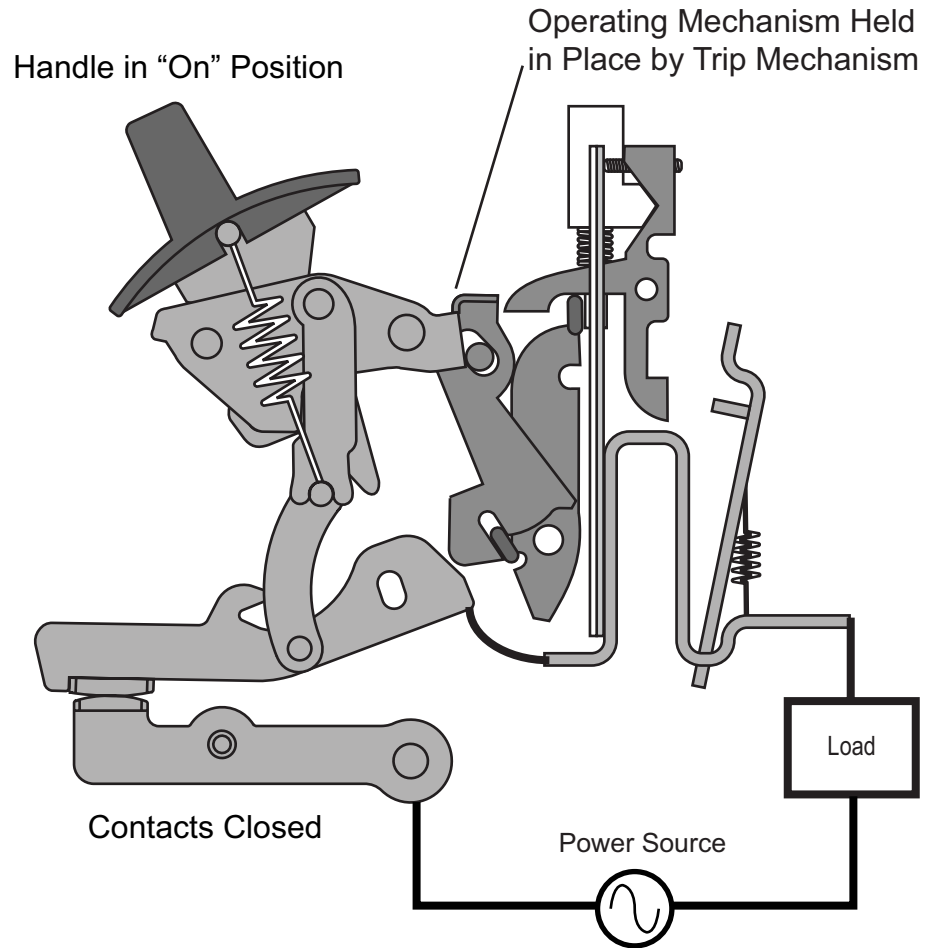

## Manual Trip

Some molded case circuit breakers, especially larger breakers, can be manually tripped by pressing the "PUSH TO TRIP" button on the face of the circuit breaker. When the button is pressed the tripper bar rotates up and to the right. This allows the trip mechanism to "unlock" releasing the operating mechanism. The operating mechanism opens the contacts.

The "PUSH TO TRIP" button also serves as a safety device by preventing access to the circuit breaker interior in the "ON" position. If an attempt is made to remove the circuit breaker cover while the contacts are in the closed ("ON") position, a spring located under the pushbutton causes the button to lift up and the breaker to trip.

Operating Mechanism  
Released by Trip Mechanism

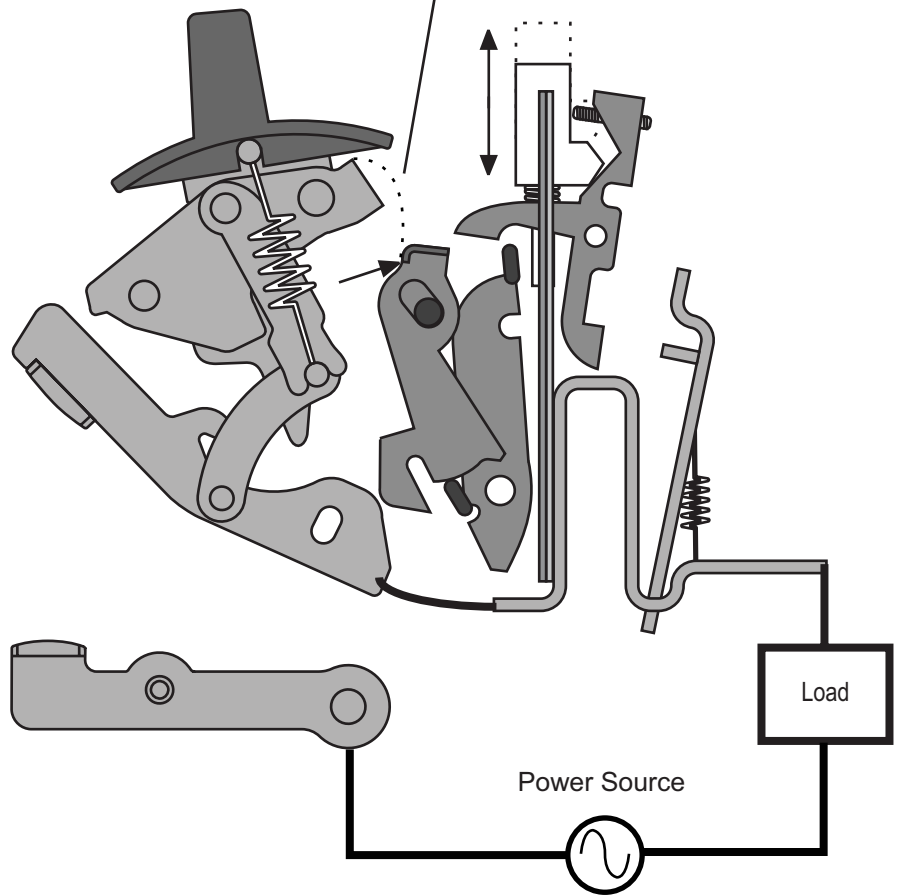

## Overload Trip

Thermal-magnetic circuit breakers employ a **bi-metallic strip** to sense overload conditions. When sufficient overcurrent flows through the circuit breaker's current path, heat build up causes the bi-metallic strip to bend. After bending a predetermined distance, the bi-metallic strip makes contact with the tripper bar activating the trip mechanism.

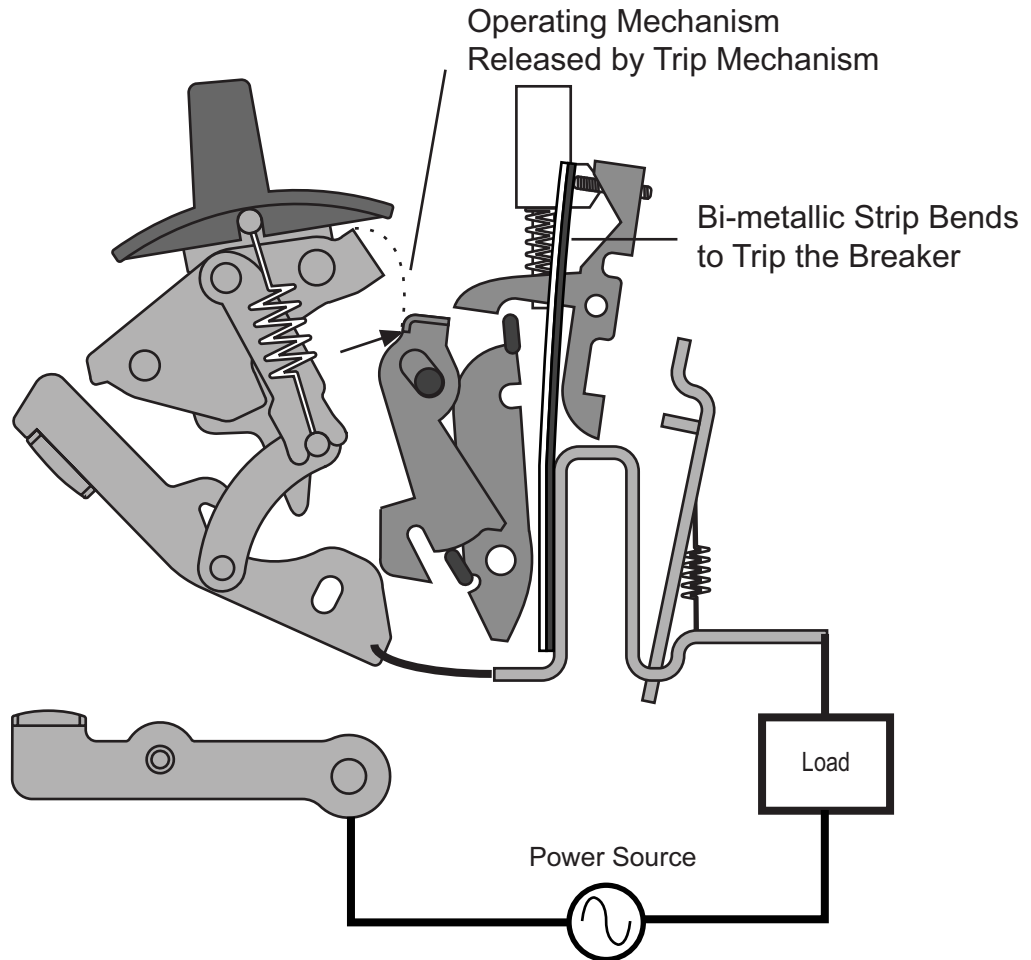

A bi-metallic strip is made of two dissimilar metals bonded together. The two metals have different thermal expansion characteristics, so the bi-metallic strip bends when heated. As current rises, heat also rises. The hotter the bi-metallic becomes the more it bends.

After the source of heat is removed, as when the circuit breaker contacts open, the bi-metallic strip cools and returns to its original condition. This allows a circuit breaker to be manually reset once the overload condition has been corrected.

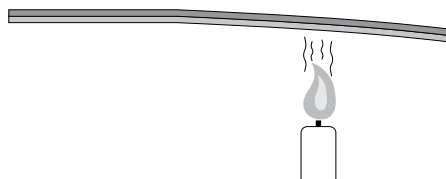

## Short Circuit Trip

As previously described, current flow through a circuit breaker's blow-apart contacts creates opposing magnetic fields. Under normal operating conditions, these opposing forces are not sufficient to separate the contacts. When a short circuit occurs, however, these opposing forces increase significantly.

The current that flows through the contacts also flows through a conductor that passes close to the circuit breaker's trip unit. At fault current levels, the magnetic field surrounding this conductor provides sufficient force to unlatch the trip unit and trip the breaker.

The combined actions of magnetic fields forcing contacts apart while simultaneously tripping the circuit breaker result in rapid interruption of the fault current. In addition, because the magnetic forces are proportional to the current, the greater the fault current, the shorter the time it takes to interrupt the current.

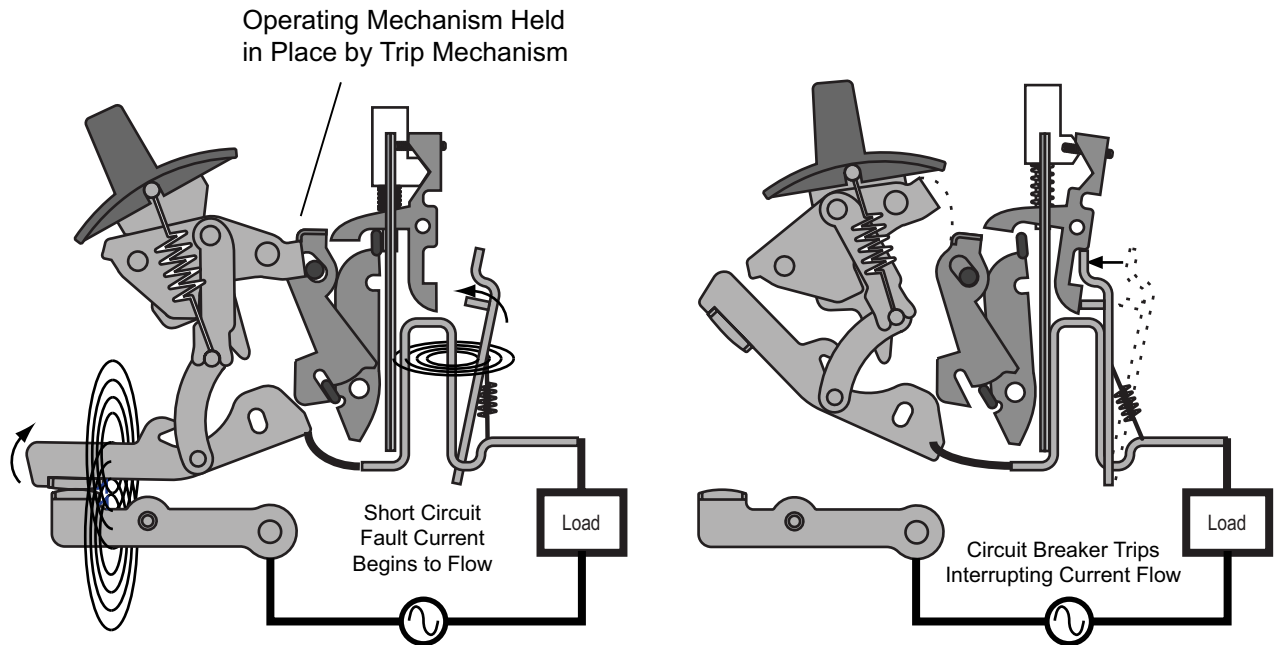

## Review 2

1. When a circuit breaker is turned off or is tripped by a fault current, the circuit breaker interrupts the flow of current by separating its \_\_\_\_\_.
2. Siemens developed the \_\_\_\_\_ - \_\_\_\_\_ contact design that greatly reduces the amount of time it takes for breaker contacts to open when a fault occurs.
3. The \_\_\_\_\_ \_\_\_\_\_ assembly reduces contact damage by dividing the arc into smaller segments which can be extinguished faster.
4. Siemens circuit breakers use an \_\_\_\_\_ - \_\_\_\_\_ toggle mechanism that is a quick-make and quick-break design.
5. A \_\_\_\_\_ strip uses two dissimilar metals bonded together.
6. In a thermal-magnetic circuit breaker, a \_\_\_\_\_ field is used to trip the circuit breaker when a short circuit is sensed.

# Types of Circuit Breakers

## Instantaneous Magnetic-Trip-Only Circuit Breakers

As the name indicates, **instantaneous magnetic-trip-only circuit breakers** provide short circuit protection but do not provide overload protection. This type of circuit breaker is typically used in motor control applications where overload protection is provided by an the overload relay.

For example, in the circuit shown below, a three-pole instantaneous magnetic-trip-only circuit breaker provides short circuit protection while the overload protection for the motor is provided by an overload relay which is part of a motor starter.

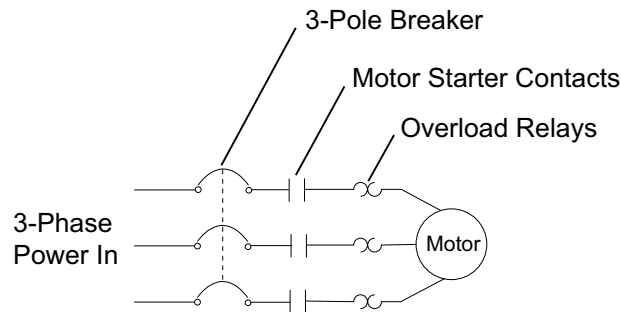

## Thermal-Magnetic, Circuit Breakers

This type of circuit breaker is called a **thermal-magnetic circuit breaker** because it has a trip unit that senses heat to detect an overload and senses a magnetic field generated by current to detect a short circuit.

As described in the Circuit Breaker Design portion of this book, this type of circuit breaker trips immediately when a short circuit occurs, but delays an appropriate amount of time before tripping in the event of an overload.

## Interchangeable Trip Circuit Breakers

The user cannot change the trip unit on many circuit breakers, but some circuit breakers have an **interchangeable trip** feature. This feature allows the user to change the continuous current rating of the breaker without replacing the breaker. This is done by replacing the trip unit with one of a different rating.

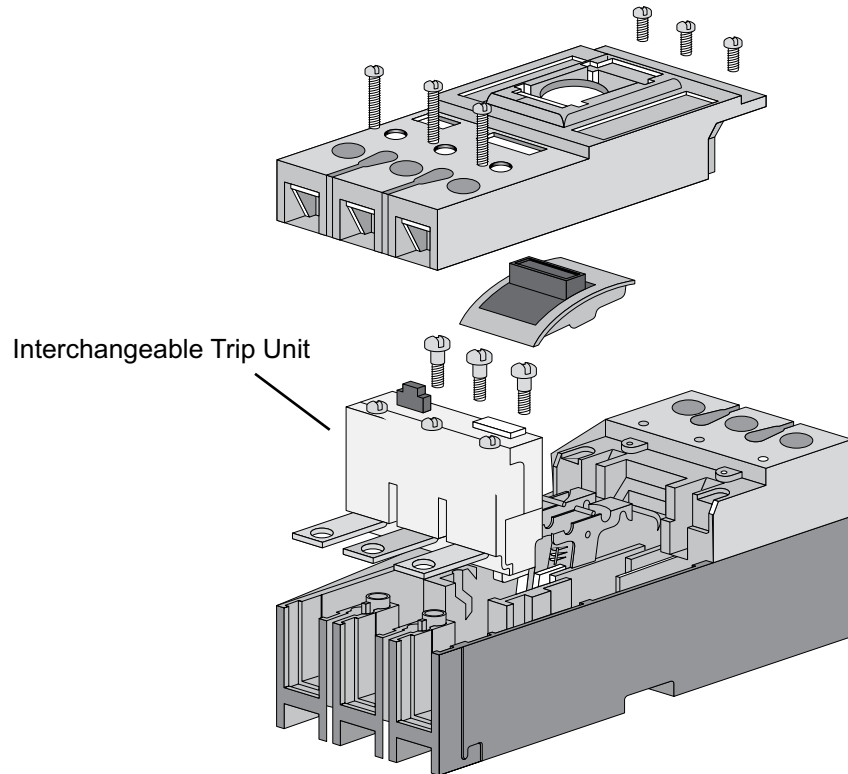

**Note:** Care must be exercised when considering interchangeable trip circuit breakers. A circuit breaker may be listed by Underwriters Laboratories, Inc.® (UL®) for a specific interchangeable trip unit only. Circuit breaker frames are usually designed to prevent the installation of an improper trip unit size or type.

## Molded Case Switch

Siemens **molded case switches** employ the same operating mechanism as the thermal-magnetic and magnetic only units. However, a preset instantaneous function is factory installed to allow the switch to trip and protect itself at a high fault current, but the switch provides no thermal overload protection or short circuit protection.



## Current Limiting Circuit Breakers

Many electrical power distribution systems can deliver large short circuit currents to electrical equipment. This high current can cause extensive damage. **Current limiting circuit breakers** protect expensive equipment by significantly reducing the current flowing in the faulted circuit.

One way to accomplish current limiting is with an additional set of contacts that feature two moveable arms. These are referred to as dual-pivot contacts, which separate even more quickly than the single-pivot contacts. The dual-pivot contacts are connected in series with the single-pivot contacts. As with the single-pivot design, current flows in opposite directions through the contact arms, creating a magnetic repulsion. As current increases, the magnetic repulsion force increases.

In an overload condition where current may only be one to six times normal current, the contacts remain closed until the breaker trips. When a short circuit occurs, fault current is extremely high and both sets of contact arms open simultaneously, generating high impedance arcs. The contact gap of the dual-pivot contacts increases more rapidly, therefore generating arc impedance more rapidly. Once the arcs are extinguished, the dual-pivot contacts close on their own due to spring tension. The single-pivot contacts are held open by the breaker mechanism, which will have tripped during the fault and must be manually reset.

The frame on current limiting circuit breakers of this design is extended to allow room for the dual-pivot set of contacts. Siemens current limiting breakers can handle fault currents of up to 200,000 amps.

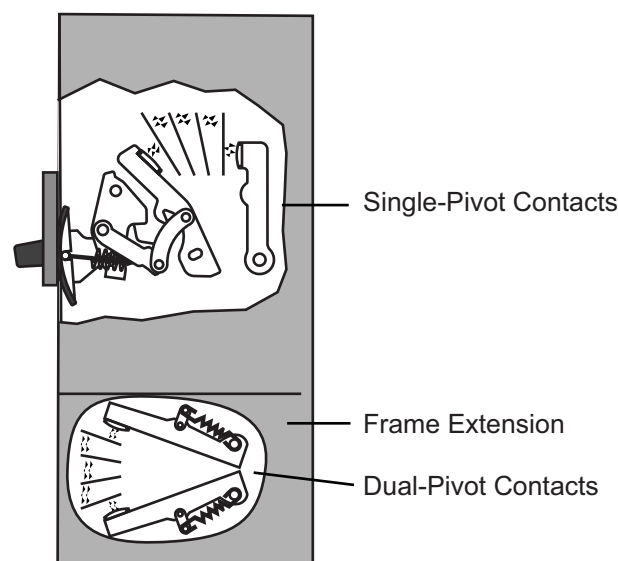

## Solid State Circuit Breakers

**Solid state circuit breakers** function similarly to thermal-magnetic breakers and have a mechanical breaker mechanism, but incorporate a solid state trip unit. The solid state trip unit allows this type of circuit breaker to have programmable features and a greater degree of accuracy and repeatability.

Similar to other types of trip units, the solid state trip unit:

- Senses magnitude of current flow
- Determines when current becomes excessive
- Determines when to send a trip signal to the breaker mechanism

The brains of a solid state trip unit is a **microprocessor**. Adjustments on the trip unit allow the user to select numerical values the microprocessor will use in performing protective functions. Current sensors mounted in the trip unit monitor the value of load current. The value of current is reduced to a low level and converted to a digital voltage, which is used by the microprocessor. The microprocessor continuously compares the line current with the value set by the user. When current exceeds a preset value for the selected time, the trip unit sends a signal to a magnetic latch. The magnetic latch opens the breaker's contacts, disconnecting the protected circuit from the power source.

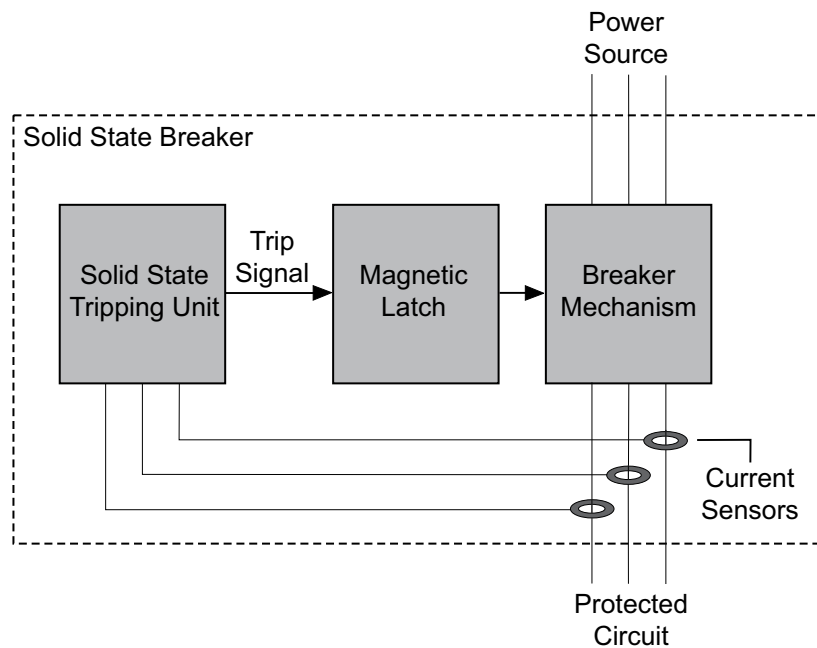

# Circuit Breaker Ratings

## Voltage Rating

Circuit breakers are rated according to the maximum voltage they can handle. The **voltage rating** of the circuit breaker must be at least equal to the circuit voltage. The voltage rating of a circuit breaker can be higher than the circuit voltage, but never lower. For example, a 480 VAC circuit breaker could be used on a 240 VAC circuit. A 240 VAC circuit breaker could not be used on a 480 VAC circuit. The voltage rating is a function of the circuit breaker's ability to suppress the internal arc that occurs when the circuit breaker's contacts open.

Some circuit breakers have what is referred to as a "slash" voltage rating, such as 120/240 volts. In such cases, the breaker may be applied in a circuit where the nominal voltage between any conductor and ground does not exceed the lower rating and the nominal voltage between conductors does not exceed the higher rating.

## Continuous Current Rating

Every circuit breaker has a **continuous current rating** which is the maximum continuous current a circuit breaker is designed to carry without tripping. The current rating is sometimes referred to as the **ampere rating** because the unit of measure is amperes, or, more simply, amps.

The rated current for a circuit breaker is often represented as  $I_n$ . This should not be confused with the current setting ( $I_r$ ) which applies to those circuit breakers that have a continuous current adjustment.  $I_r$  is the maximum continuous current that circuit breaker can carry without tripping for the given continuous current setting.  $I_r$  may be specified in amps or as a percentage of  $I_n$ .

As mentioned previously, conductors are rated for how much current they can carry continuously. This is commonly referred to as the conductor's ampacity. In general, the ampere rating of a circuit breaker and the ampacity of the associated conductors must be at least equal to the sum of any non-continuous load current plus 125% of the continuous load current.

Siemens circuit breakers are rated on the basis of using 60° C or 75° C conductors. This means that even if a conductor with a higher temperature rating were used, the ampacity of the conductor must be figured on its 60° C or 75° C rating.

## Frame Size

The circuit breaker frame includes all the various components that make up a circuit breaker except for the trip unit. For any given frame, circuit breakers with a range of current ratings can be manufactured by installing a different trip unit for each rating. The breaker **frame size** is the highest continuous current rating offered for a breaker with a given frame.

## Interrupting Rating

Circuit breakers are also rated according to the maximum level of current they can interrupt. This is the **interrupting rating** or **ampere interrupting rating (AIR)**. Because UL and IEC testing specifications are different, separate UL and IEC interrupting ratings are usually provided.

When designing an electrical power distribution system, a main circuit breaker must be selected that can interrupt the largest potential fault current that can occur in the selected application. The interrupting ratings for branch circuit breakers must also be taken into consideration, but these interrupting ratings will depend upon whether series ratings can be applied. Series-connected systems are discussed later in this course.

The interrupting ratings for a circuit breaker are typically specified in **symmetrical RMS amperes** for specific rated voltages. As discussed in **Basics of Electricity**, RMS stands for root-mean-square and refers to the effective value of an alternating current or voltage. The term symmetrical indicates that the alternating current value specified is centered around zero and has equal positive and negative half cycles. Siemens circuit breakers have interrupting ratings from 10,000 to 200,000 amps.

These and other ratings for Siemens circuit breakers can be found in the SPEEDFAX catalog which is available in print form as well as on the Siemens Energy & Automation web site: [www2,sea.siemens.com](http://www2.sea.siemens.com).

# Time-Current Curves

**Time-current curves**, similar to the one shown on the following page, are used to show how fast a breaker will trip at any magnitude of current. The following illustration shows how to read a time-current curve. The figures along the bottom (horizontal axis) represent multiples of the continuous current rating ( $I_n$ ) for the breaker. The figures along the left side (vertical axis) represent time in seconds.

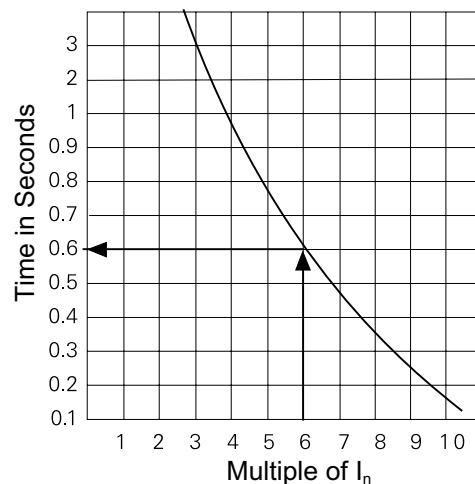

To determine how long a breaker will take to trip at a given multiple of  $I_n$ , find the multiple on the bottom of the graph and draw a vertical line to the point where it intersects the curve. Then draw a horizontal line to the left side of the graph and find the time to trip. For example, in this illustration a circuit breaker will trip when current remains at six times  $I_n$  for .6 seconds. Note that the higher the current, the shorter the time the circuit breaker will remain closed. Time-current curves are usually drawn on log-log paper. Many time-current curves also show the bandwidth, tolerance limits, of the curve.

From the information box in the upper right hand corner, note that the time-current curve illustrated on the next page defines the operation of a Siemens MG frame circuit breaker. For this example, operation with an 800 ampere trip unit is shown, but, depending upon the specific breaker chosen, this circuit breaker may be purchased with a 600, 700, or 800 amp continuous current rating.

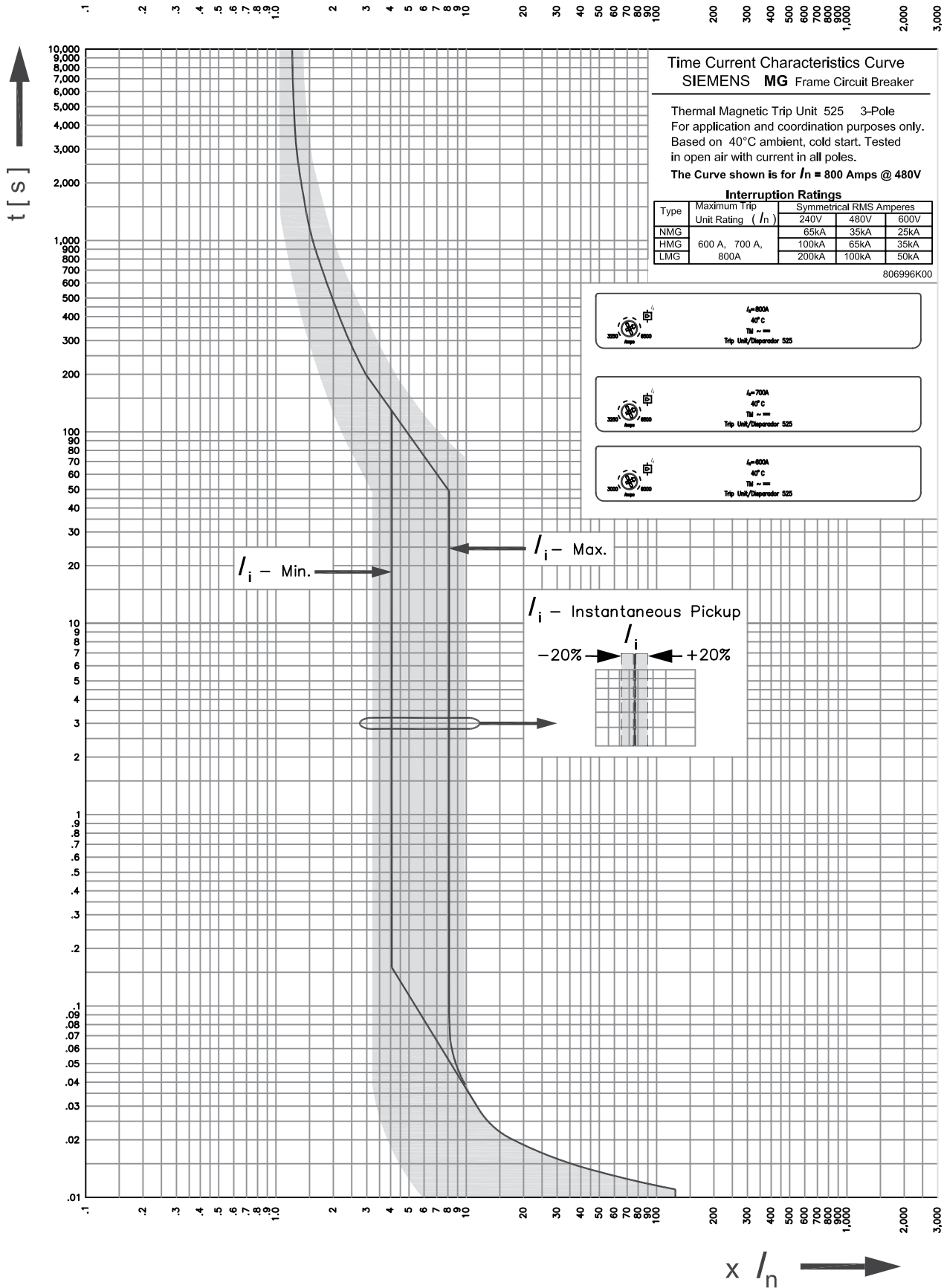

## Overload Protection

The top part of the time-current curve shows the continuous current performance of the circuit breaker. The black line shows the nominal performance of the circuit breaker and the gray band represents possible variation from this nominal performance that can occur even under specified conditions.

Using the example of an MG breaker with an 800 amp continuous current rating ( $I_n$ ), note that the circuit breaker can be operated at 800 amps (1.0 times  $I_n$ ) indefinitely without tripping. However, the top of the trip curve shows that an overload trip will occur in 10,000 seconds at 1000 amps (1.25 times  $I_n$ ). Additionally, the gray area on either side of the trip curve shows the range of possible variation from this response.

Keep in mind that this trip curve was developed based upon predefined specifications, such as operation at a 40°C ambient temperature. Variations in actual operating conditions will result in variations in circuit breaker performance.

## Instantaneous Trip

The middle and bottom parts of this time-current curve show instantaneous trip (short circuit) performance of the circuit breaker. Note that the maximum clearing time (time it takes for the breaker to completely open) decreases as current increases. This is because of high-speed contact designs which utilize the magnetic field built up around the contacts. As current increases, the magnetic field strength increases, which speeds the opening of the contacts.

This circuit breaker has an adjustable instantaneous trip point from 3250 to 6500 amps, which is approximately four to eight times the 800 amp continuous current unit rating. This adjustment affects the middle portion of the trip curve, but not the top and bottom parts of the curve. The breaker shown in this example has a thermal-magnetic trip unit. Circuit breakers with solid-state trip units typically have additional adjustments.

# Selective Coordination

**Selective coordination** is the application of circuit protective devices in series such that under overload or fault conditions, only the upstream device nearest the fault will open. The rest of the devices remain closed, leaving other circuits unaffected. In the following example a short circuit has occurred in the circuit fed by branch circuit breaker "C." Power is interrupted to equipment supplied by circuit breaker "C" only. All other circuits remain unaffected.

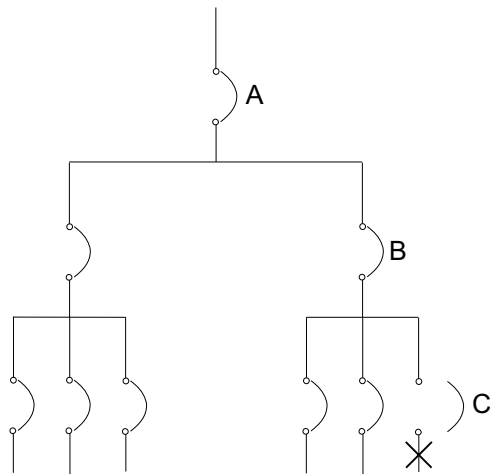



## Circuit Breaker Coordination

Time current curves are useful for coordinating circuit breakers. If the trip curves of main breaker "A," feeder breaker "B," and branch breaker "C" are placed on the same graph, there should be no overlapping, indicating the breakers are coordinated. The three circuit breakers in the following example have been coordinated so that for any given fault value, the tripping time of each breaker is greater than tripping time for the downstream breaker(s). In the following illustration, circuit breaker "C" is set to trip if a 400 amp fault current remains for .04 seconds. Circuit breaker "B" will trip if the fault remains for .15 seconds, and circuit breaker "A" if the fault remains for .8 seconds. If a 400 amp fault occurs downstream from circuit breaker "C," it will trip first and clear the fault. Circuit breakers "A" and "B" will not trip.

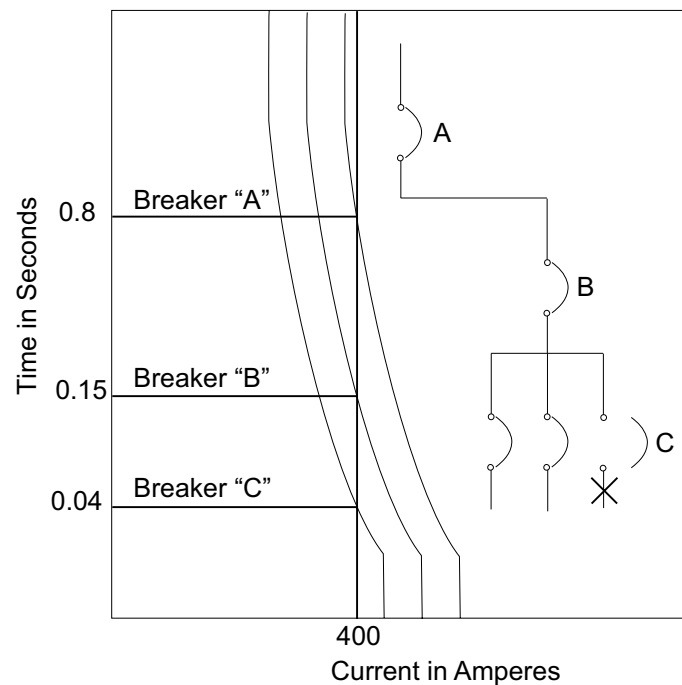

# Series-Connected Systems

When selecting circuit breakers, it is extremely important to know both the maximum continuous amperes and the available fault current. *NEC*<sup>®</sup> article 110.9 states:

*Equipment intended to interrupt current at fault levels shall have an interrupting rating sufficient for the nominal circuit voltage and the current that is available at the line terminals of the equipment.*

*Equipment intended to interrupt current at other than fault levels shall have an interrupting rating at nominal circuit voltage sufficient for the current that must be interrupted.*

There are two ways to meet this requirement. The first method is to select circuit breakers with individual ratings equal to or greater than the available fault current. This means that, in the case of a building with 65,000 amperes of fault current available at the service entrance, every circuit breaker must have an interrupting rating of at least 65,000 amperes.

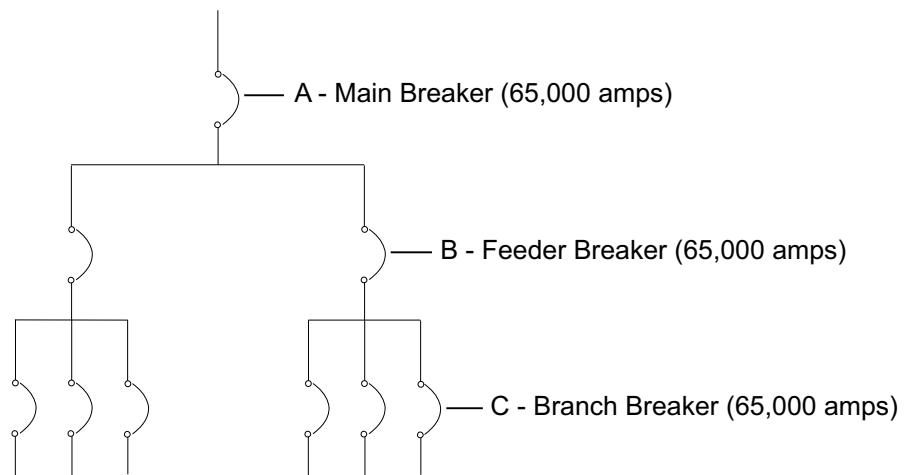

*Reprinted with permission from NFPA 70<sup>®</sup>-2008, National Electrical Code<sup>®</sup>, Copyright © 2008, National Fire Protection Association, Quincy, MA 02169. This reprinted material is not the complete and official position of the National Fire Protection Association on the referenced subject, which is represented only by the standard in its entirety.*

The second method is to select circuit breakers with a **series combination rating** equal to or greater than the available fault current at the service entrance. The series-rated concept requires the main upstream breaker to have an interrupting rating equal to or greater than the available fault current of the system, but subsequent downstream breakers connected in series can be rated at lower values. For example, a building with 65,000 amperes of available fault current might only need the breaker at the service entrance to have an interrupting rating of 65,000 amperes. Additional downstream breakers can be rated at lower values. The series combination must be tested and listed by UL.

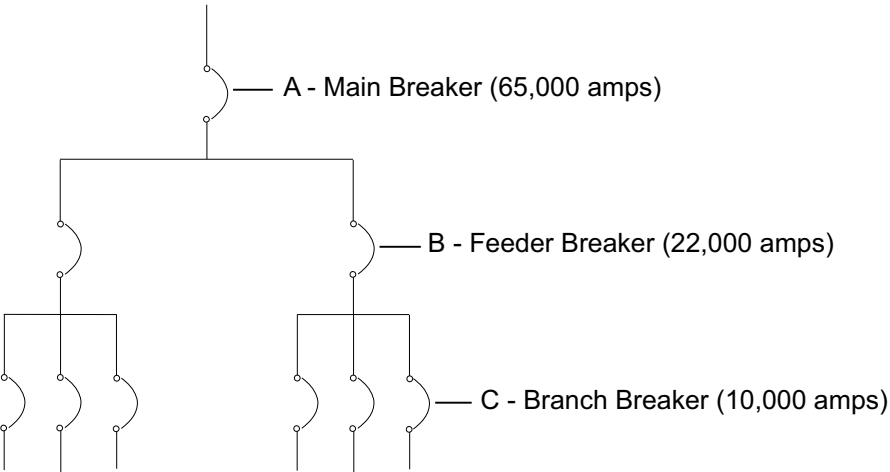

Siemens series-rated breakers are listed under "Series Connected Short Circuit Ratings" in the Siemens SPEEDFAX® catalog. Your Siemens sales engineer can provide more information on Siemens series-rated circuit breakers.

### Review 3

1. \_\_\_\_\_ magnetic-trip-only circuit breakers protect against short circuits, but provide no overload protection.
2. \_\_\_\_\_-magnetic circuit breakers have both overload and instantaneous trip features.
3. Siemens current limiting circuit breakers can interrupt up to \_\_\_\_\_ amps.
4. The maximum continuous current a circuit breaker can carry is known as its \_\_\_\_\_ rating.
5. The upper part of a time-current curve represents the \_\_\_\_\_ component, while the lower part of a time-current curve represents the instantaneous trip component.
6. Circuit breaker \_\_\_\_\_ will allow the circuit breaker supplying a circuit that faults to trip, but all upstream circuit breakers will remain unaffected.

# Siemens Circuit Breakers

Siemens offers a broad selection of circuit breakers. The remainder of this course provides a brief overview of Siemens circuit breakers that fall into the following categories.

**Residential circuit breakers** - this category includes main and branch circuit breakers intended for use in Siemens load centers and other enclosures used in residential and light commercial applications.

**Panelboard circuit breakers** - this category includes a few thermal-magnetic molded case circuit breaker types used in Siemens panelboards.

**General purpose thermal-magnetic circuit breakers** - this category includes thermal-magnetic molded case circuit breakers in various frame sizes with continuous current ratings up to and including 2000 amps.

**Solid-state trip unit circuit breakers** - this category includes molded case circuit breakers with solid-state trip units in various frame sizes with continuous current rating up to and including 1600 amps.

**VL circuit breakers** - this category includes Siemens newest molded case circuit breakers which are currently available in various frame sizes up to and including 1600 amps. VL circuit breakers can be equipped either with a thermal-magnetic trip unit or a solid-state trip unit.

**WL circuit breakers** - this category includes Siemens newest 3-pole power circuit breakers available in three frame sizes with continuous current ratings from 200 to 5000 amps.

Because this course is intended to provide only an overview of Siemens circuit breakers, some Siemens circuit breaker types are not included. However, understanding the types of circuit breakers summarized on the following pages will provide you with a good foundation for further study. Refer to the SPEEDFAX catalog and the Siemens Energy & Automation web site for additional information.

# Residential Circuit Breakers

Residential circuit breakers are typically 1, 2 or 4-pole breakers with current ratings of 225 amps or less and voltage ratings of 120 volts, 120/240 volts, or 240 volts. Because residential circuit breakers are also used in commercial applications and many commercial applications require 3-pole breakers, some 3-pole breakers are also included in this category.

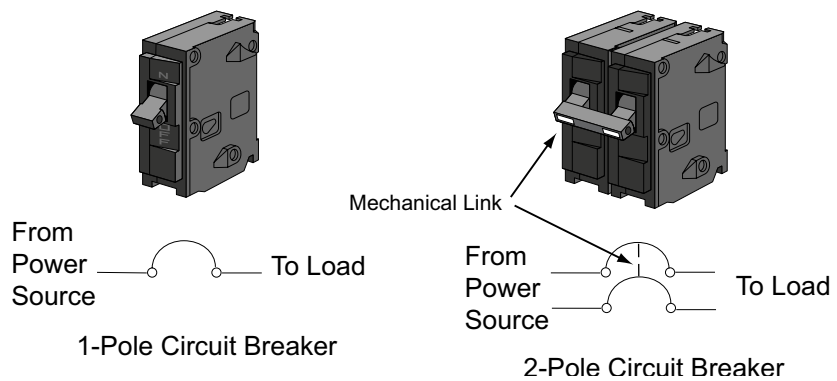

Residential circuit breakers are normally plug-in types that mount in load centers or other enclosures.

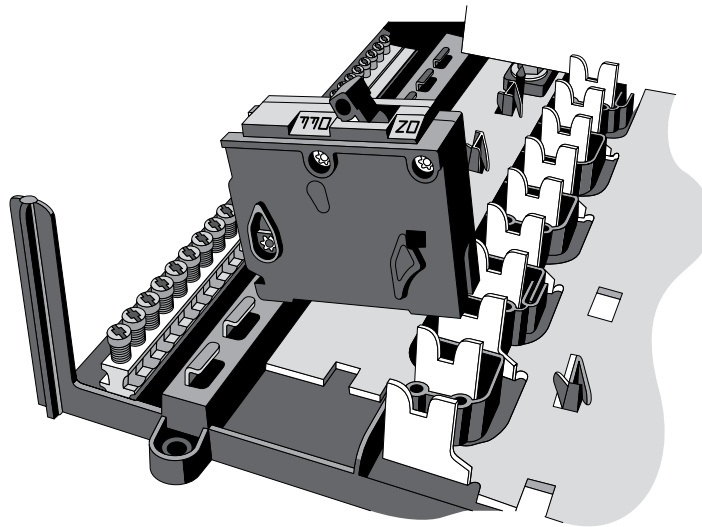

In addition to thermal-magnetic circuit breakers intended for use as main or branch circuit breakers in residential applications, Siemens offers branch circuit breakers with arc-fault circuit interruption, ground-fault circuit interruption, or point of entry surge protection. Circuit breakers are also available for a number of special applications. All Siemens residential circuit breakers provide overload and short circuit protection. Because of the variety of circuit breakers offered, this section describes only representative examples. Refer to the SPEEDFAX catalog for additional information.

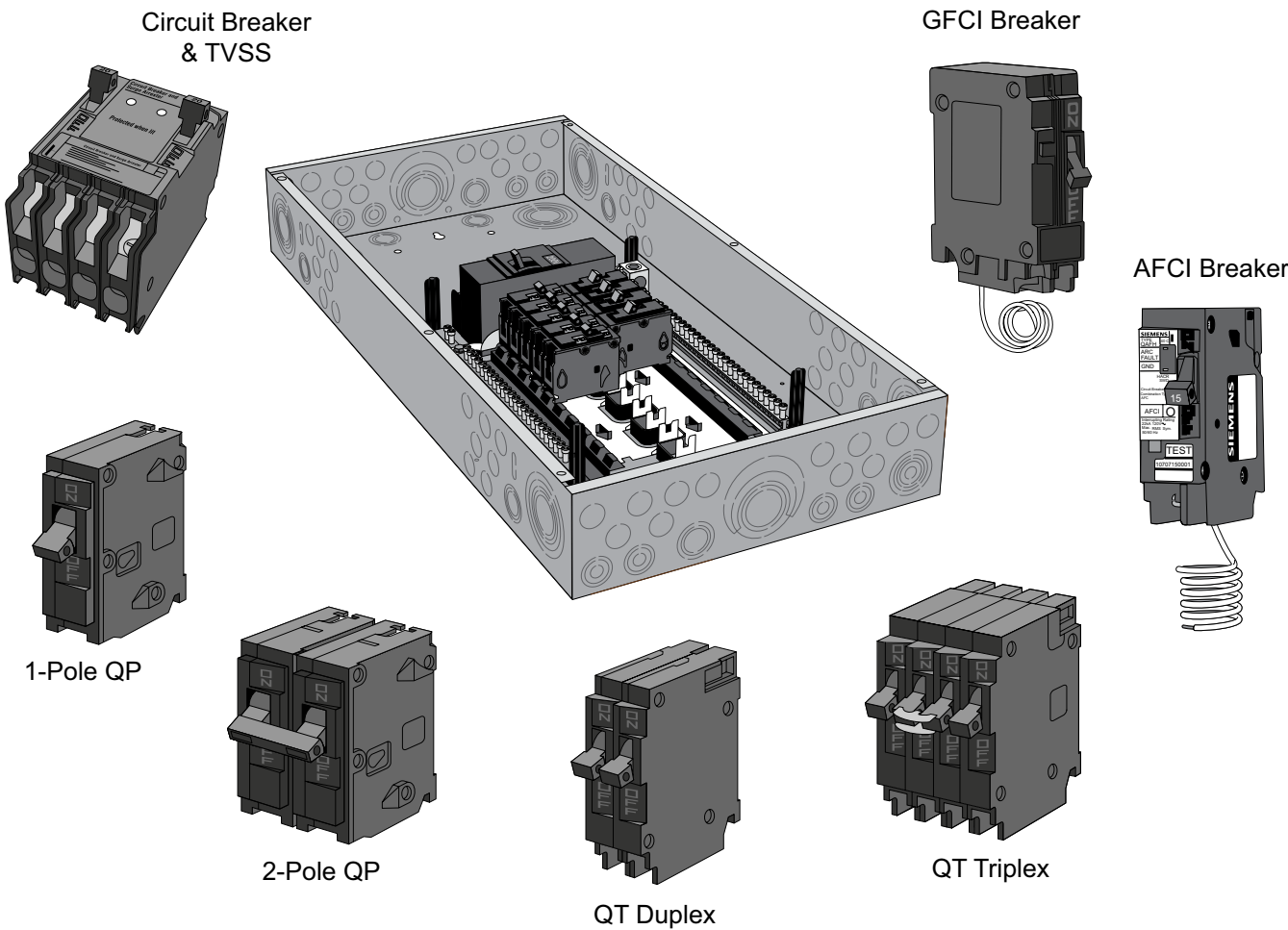

**Main Breakers**

Siemens offers a wide selection of load centers and enclosures equipped with a **main circuit breaker** as well as **main lug** load centers that are convertible to main breaker load centers through use of a main breaker kit. The specifications for these load centers and enclosures vary. However, Siemens Ultimate load center provides a representative example.

**Ultimate load centers** are available as main lug or main breaker load centers, but main lug load centers are convertible to main breaker load centers and vice versa. The main breakers or main breaker kits for these load centers have continuous current ratings from 100 to 225 amps. The interrupting rating for these main breakers is 22 kA. Single-phase, factory-installed 22 kA interrupting rating main circuit breakers offer a 22/10 kA series combination interrupting rating when used with 10 kA type QP, QT, QPF, QE, QN and QAF branch breakers.

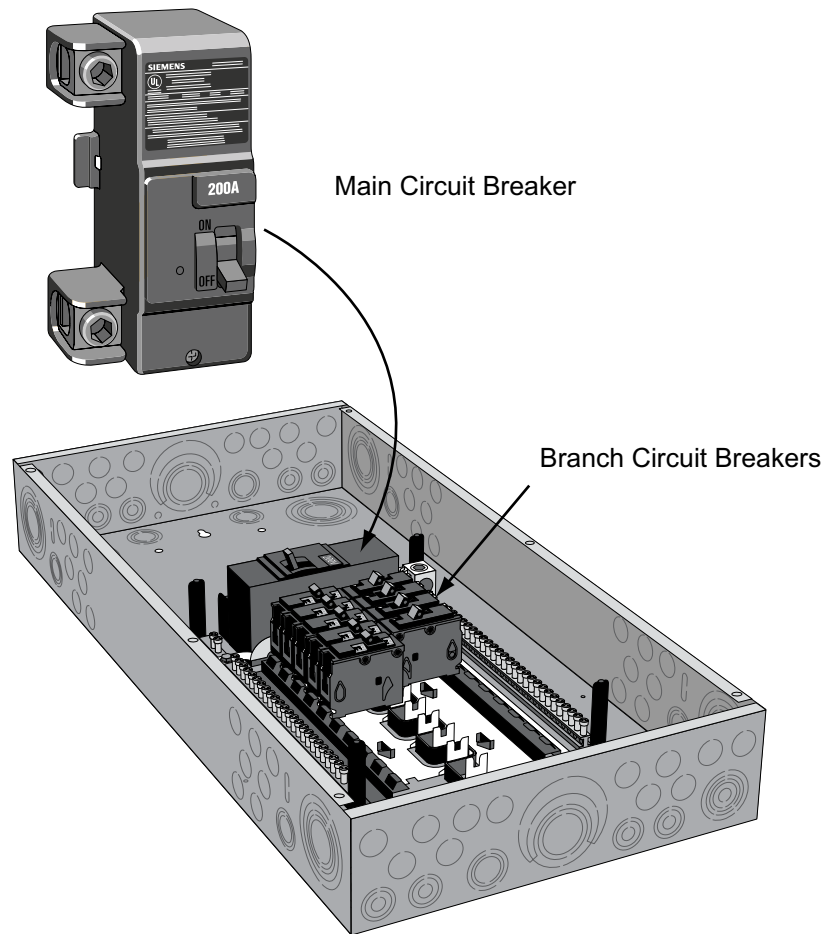

### Branch Circuit Breakers

Because Siemens offers a complete selection of load centers and other enclosures, and application requirements for circuit breakers vary, multiple **branch circuit breaker** types are also needed. However, Siemens type QP and QT circuit breakers discussed in this course provide a representative sampling.



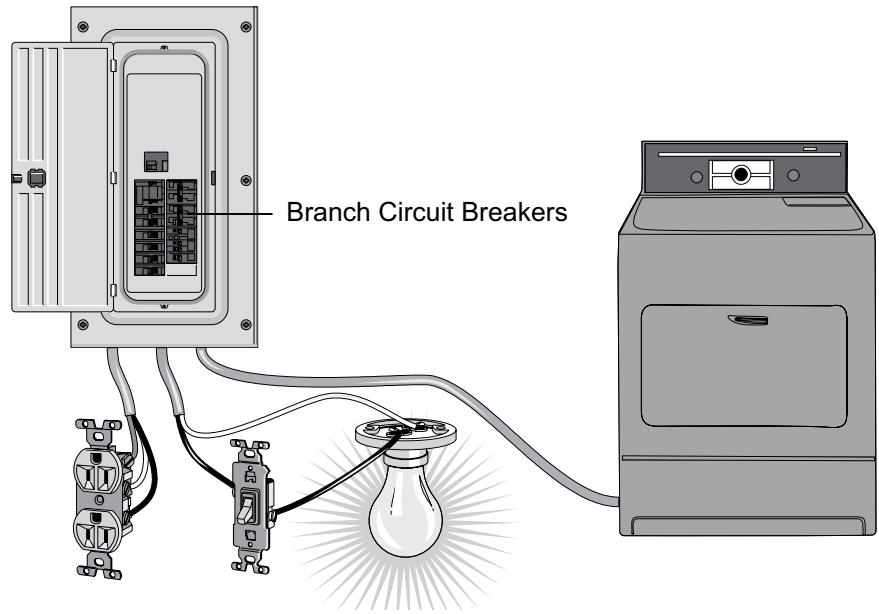

## QP Circuit Breakers

**Type QP circuit breakers** are available as 1-pole, 2-pole, or 3-pole breakers. 2-pole and 3-pole varieties have a common trip unit so that all breaker poles are tripped at the same time.

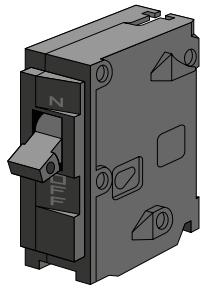

1-Pole, 1" Width  
Requires 1 Space

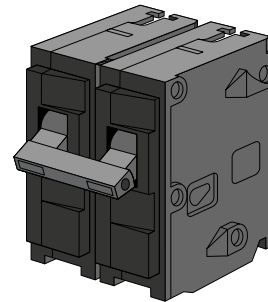

2-Pole, 2" Width  
Requires 2 Spaces

1-pole QP breakers are rated for 120 VAC and have continuous current ratings from 10 to 70 amps.

2-pole QP breakers are available with a 120/240 VAC rating or a 240 VAC rating. 2-pole 120/240 VAC QP breakers have continuous current ratings from 10 to 125 amps and 2-pole 240 VAC QP breakers have continuous current ratings from 15 to 100 amps.

3-pole QP breakers are rated for 240 VAC and have continuous current ratings from 10 to 100 amps.

All type QP circuit breakers have a 10 kA interrupting rating; however, Siemens also offers type QPH circuit breakers with a 22 kA interrupting rating and type HQP circuit breakers with a 65 kA interrupting rating.

## QT Circuit Breakers

Some Siemens load centers are designed to accept **type QT Duplex, Triplex, and Quadplex plug-in circuit breakers**.

These breakers are space saving breakers that are half the width per pole of type QP circuit breakers. This reduced width allows more circuits to be serviced from a load center provided that the main circuit breaker has sufficient capacity. An important use for QT breakers is in cases where additional circuits are being added to an existing load center, but the number of spaces available in the load center is limited.

### Type QT Duplex Circuit Breakers

Type QT Duplex circuit breakers combine two independent half-inch width breaker poles in a common unit. This unit plugs into one load center stab and requires one panel space.

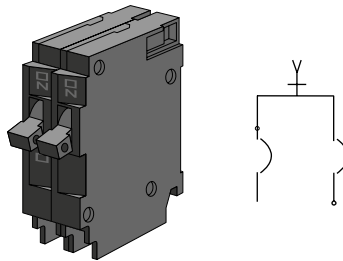

Two Independent, 1-Pole Breakers  
Requires 1 Space

### QT Triplex and QT Quadplex Circuit Breakers

Type QT circuit breakers are also available in triplex and quadplex configurations. Triplex circuit breakers provide a 2-pole circuit breaker for 120/240 VAC circuits and two independent, 1-pole circuit breakers for 120 VAC circuits. Quadplex circuit breakers incorporate two common trip, 2-pole circuit breakers for 120/240 VAC circuits. Each Quadplex or Triplex circuit breaker requires two panel spaces.

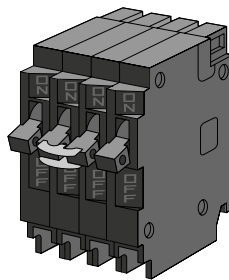

QT Triplex

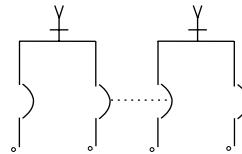

QT Triplex  
Two Independent, 1-Pole Breakers  
One Common Trip, 2-Pole Breaker  
Requires Two Spaces

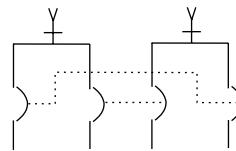

QT Quadplex  
Two Sets of Common Trip, 2-Pole Breakers  
Requires Two Spaces

## Ground Fault Circuit Interrupter (GFCI) Circuit Breakers

A **ground fault** occurs when a current-carrying conductor comes in contact with ground. A **ground fault circuit interrupter (GFCI)** compares current on the hot wire with current returning on the neutral wire. Under normal circumstances these currents are equal. Siemens Type QPF and QPHF GFCI circuit breakers provide personnel protection by de-energizing a circuit when a ground fault current of 6 ma or more is sensed.

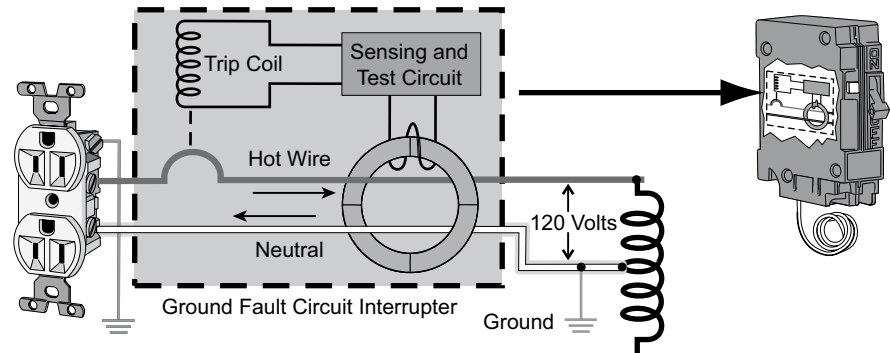

Siemens also offers Type QE and QEH circuit breakers which provide protection of equipment from damaging line-to-ground faults by de-energizing a circuit when a ground fault current of 30 ma or more is sensed.

## Arc Fault Circuit Interrupter (AFCI) Circuit Breakers

An **arc fault circuit interrupter (AFCI) circuit breaker**, in addition to providing overcurrent protection, is intended to provide protection from the effects of arc faults by recognizing the characteristics unique to arcing and de-energizing the circuit when an arc fault is detected.

There are two categories of AFCI circuit breakers on the market, branch/feeder AFCI circuit breakers and combination AFCI circuit breakers. The first AFCI circuit breakers developed were **branch/feeder AFCI circuit breakers** that, in addition to providing overcurrent protection, are intended to protect branch and feeder wiring from the damaging effects of line-to-ground arcs and high energy parallel arcs. High energy parallel arcs are line-to-neutral arcs greater than or equal to 75 A.

More recently, **combination AFCI circuit breakers** have been developed. Combination AFCI circuit breakers, in addition to providing overcurrent protection, are intended to protect downstream wiring from three categories of arc faults: line-to-ground arcs, high energy parallel arcs, and series arcs greater than or equal to 5 A. Series arcs are arcs on a single conductor.

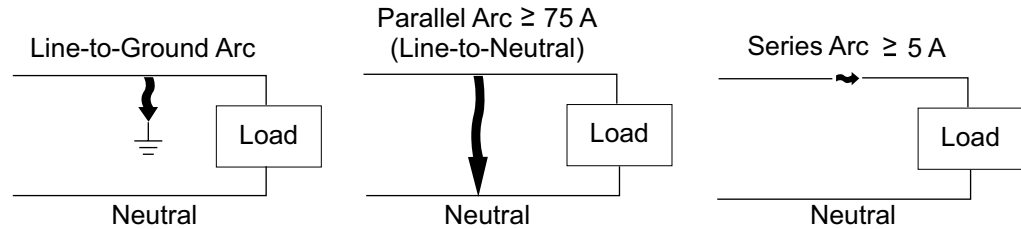

The 1999 *NEC*<sup>®</sup> required arc fault interrupter protection in new construction for 125 V, single phase, 15 A and 20 A branch circuits supplying dwelling unit bedrooms. The 2005 *NEC*<sup>®</sup> allowed branch/feeder AFCIs to provide this protection until January 1, 2008. Thereafter, it requires use of combination AFCIs for this application in new construction. The 2008 *NEC*<sup>®</sup> further expands use of listed, combination AFCIs for the protection of 120 V, single phase, 15 A and 20 A branch circuits supplying outlets in many rooms in a dwelling unit. For a complete list of required locations, refer to 2008 *NEC*<sup>®</sup> Article 210.12.

Siemens type QAF AFCI circuit breakers have a 10 kA interrupting rating and type QAFH AFCI circuit breakers have a 22 kA interrupting rating. Both breaker types are available in 1-pole and 2-pole versions.

Siemens AFCI circuit breakers have a white “pigtail” wire that attaches to the neutral bus and a “Test” button to check the device operation after it has been installed.

Siemens combination type AFCI circuit breakers are equipped with two LED trip indicators which help electricians and home owners identify the cause of a tripped breaker. The LED indications appear for five seconds each time the breaker is turned on and indicate whether the last trip was caused by overcurrent, an arc fault, or an arc fault to ground.

LED Indicator		Last Known Trip Condition
LED (A)	LED (B)	
OFF	OFF	Overcurrent
ON	OFF	Arc Fault
ON	ON	Arc Fault to Ground

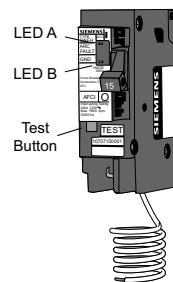

## Point-of-Entry Surge Protection

Siemens offers two devices which incorporate two 1-pole QP circuit breakers while also providing point-of-entry surge protection.

### **Siemens Circuit Breaker and Secondary Surge Arrester**

replaces two 1-pole circuit breakers in a load center and provides surge protection for all the load center's branch circuits.

### **Siemens Circuit Breaker and Transient Voltage Surge**

**Suppressor (TVSS)** also replaces two 1-pole circuit breakers and provides surge protection not only for branch circuits, but also for fixtures, appliances, motors, and other electronic equipment served by that load center.

The 1-pole type QP circuit breakers incorporated in either device are 120/240 VAC breakers with a 10 kA interrupting rating. The continuous current rating for the Circuit Breaker and TVSS is 20 amps. The Circuit Breaker and Surge Arrester is available with either 15 amp or 20 amp type QP breakers.

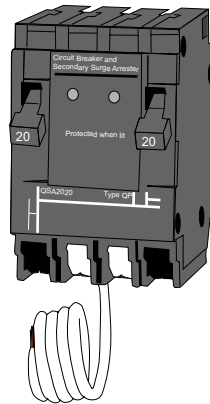

Circuit Breaker and  
Secondary Surge Arrester

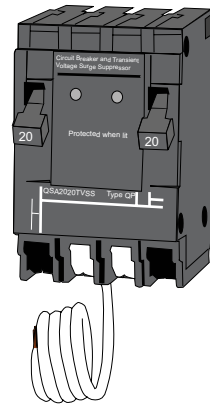

Circuit Breaker and Transient  
Voltage Surge Suppressor

# Panelboard Circuit Breakers

The majority of Siemens thermal-magnetic circuit breakers intended for commercial and industrial applications are classified in the SPEEDFAX catalog as general purpose breakers. Some of these breakers are used in panelboards; however, Siemens type BL, BLH, HBL, BQD, and BQD6 circuit breakers are intended exclusively for panelboard use. These are thermal-magnetic circuit breakers with features similar to those of the residential circuit breakers discussed previously. Whereas many of the residential breakers plug into their enclosures, the panelboard breakers listed in this section bolt on to a panelboard's power bus.

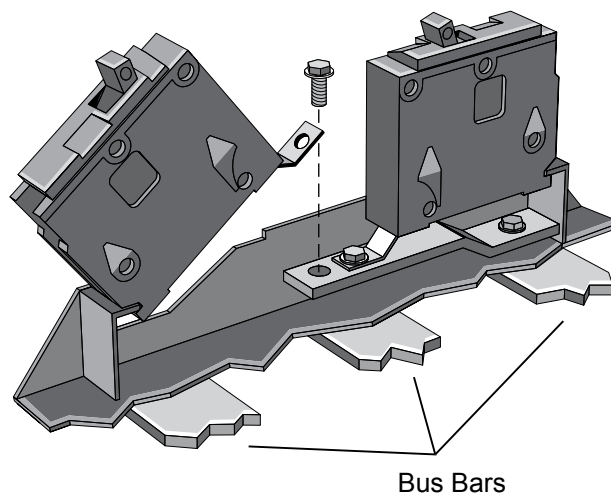

## BL, BLH, and HBL Circuit Breakers

**Type BL, BLH, and HBL circuit breakers** are available in 1-pole, 2-pole, or 3-pole versions. Also included in this category are circuit breakers that incorporate the following capabilities: ground fault circuit interruption (types BLF and BLHF), ground fault equipment protection (types BLE and BLEH), arc-fault circuit interruption (types BAF and BAFH), or switching neutrals (type BG).

Additionally, versions of the BL breaker are available which can accommodate the high inrush current associated with high-intensity discharge (HID) or tungsten lighting and a molded case switch for use where overcurrent protection is provided separately.

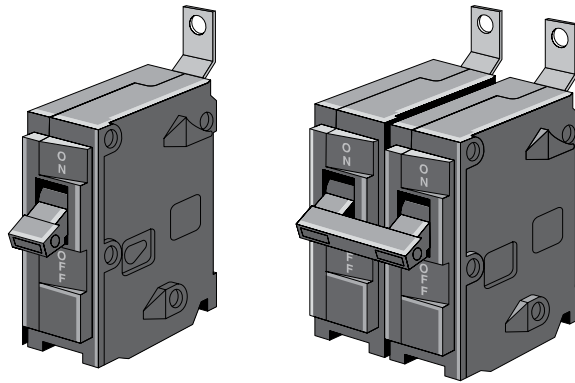

1-Pole BL Circuit Breaker    2-Pole BL Circuit Breaker

## BQD Circuit Breakers

**Type BQD and BQD6 circuit breakers** are 100 amp frame breakers available in 1-pole, 2-pole, and 3-pole versions. BQD6 breakers are CSA certified.

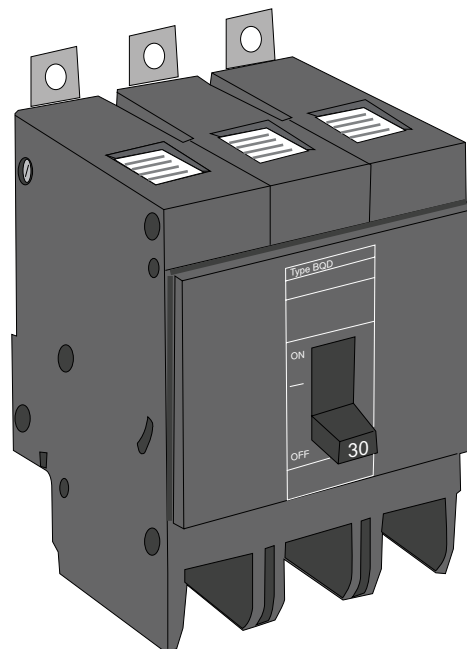

3-Pole BQD Circuit Breaker

		BL	BLH	HBL	BQD	BQD6	
	Poles	1, 2, 3	1, 2, 3	1, 2, 3	1, 2, 3	1, 2, 3	
AC	Amperes, Continuous	1-Pole	10-70	15-70	15-70	15-100	15-100
		2-Pole	10-125	15-125	15-125	15-100	15-100
		3-Pole	10-100	15-100	15-100	15-100	15-100
	Volts (50/60 Hertz)	1-Pole	120	120	120	277	347
		2-Pole	120/240	120/240	120/240	480/277	600/347
		3-Pole	240	240	240		
	UL Interrupting Rating - Symmetrical RMS Amperes	120 V	10,000	22,000	65,000	65,000	65,000
		240 V	10,000	22,000	65,000	65,000	65,000
		277 V	-	-	-	14,000	-
		347 V	-	-	-	-	-
		480/277 V	-	-	-	14,000	-
600/347 V		-	-	-	-	10,000	
DC	Volts 2-Pole	-	-	-	125/250	125/250	
	Interrupting Rating - DC Amperes	-	-	-	14,000	14,000	

2-Pole BL rated for 240 VAC available for 15-100 A only

2-pole and 3-pole BQD and BQD6 Unsuitable for 3-phase delta 480 V applications

BQD6 CSA certified 10,000 AIC @ 600Y/347 VAC, 15-70 A only

## Review 4

1. Residential circuit breakers are typically 1-pole or 2-pole breakers with current ratings of 225 amps or less and voltage ratings of \_\_\_ volts, \_\_\_/\_\_\_ volts, or \_\_\_ volts.
2. All type QP circuit breakers have a \_\_ kA interrupting rating; however, Siemens also offers type QPH circuit breakers with a \_\_ kA interrupting rating and type HQP circuit breakers with a \_\_ kA interrupting rating.
3. Type QT circuit breakers have a width of \_\_\_\_\_ per pole.
4. Siemens type \_\_\_ and \_\_\_\_\_ breakers, protect against a fire being started from an unintended arc by de-energizing a circuit when an arc-fault is detected.
5. BLF and BLHF circuit breakers provide \_\_\_\_\_ circuit interruption capability.



# General Purpose Thermal-Magnetic Circuit Breakers

For the purpose of this course, Siemens thermal-magnetic circuit breaker types BQ, CQD, NGG/NGB, EG/EB, ED, FD, JD, LD, LMD, MD, ND, PD, RD, and variants of these types are classified as general purpose circuit breakers. As such, they are used in commercial and industrial applications in a variety of enclosure types.

## BQ Circuit Breakers

**Type BQ, BQH, and HBQ plug-in circuit breakers** are available with 1, 2, or 3 poles. These circuit breakers are supplied with load-side lugs, but may be ordered with line-side lugs. Additional versions are available for DIN rail mounting.

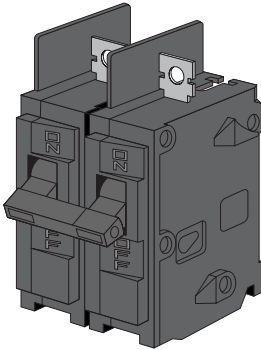

2-Pole BQ Circuit Breaker

		BQ	BQH	HBQ	
AC	Poles	1, 2, 3	1, 2, 3	1, 2, 3	
	Amperes, Continuous	1-Pole	15-70	15-70	15-70
		2-Pole	15-125	15-100	10-125
		3-Pole	10-100	15-100	10-100
	Volts (50/60 Hertz)	1-Pole	120	120	120
		2-Pole	120/240	120/240	120/240
		3-Pole	240	240	240
	UL Interrupting Rating - Symmetrical RMS Amperes	120 V	10,000	22,000	65,000
		240 V	10,000	22,000	65,000

2-Pole BQ rated for 240 VAC available for 15-100 A only

## CQD Circuit Breaker

**Type CQD circuit breakers** are 100 amp frame breakers similar to BQD circuit breakers, but equipped for DIN rail mounting. Type CQD6 breakers are CSA certified rather than UL listed.

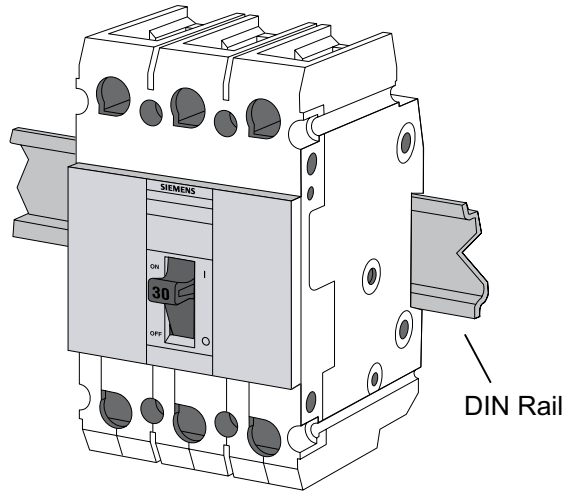

3-Pole CQD Circuit Breaker

		CQD	CQD6	
AC	Poles	1, 2, 3	1, 2, 3	
	Amperes, Continuous	1-Pole	15-100	15-70
		2-Pole	15-100	15-70
		3-Pole	15-100	15-60
	Volts (50/60 Hertz)	1-Pole	277	347
		2-Pole	480/277	600/347
		3-Pole		
	UL Interrupting Rating - Symmetrical RMS Amperes	120 V	65,000	65,000
		240 V	65,000	65,000
		480/277 V	14,000	14,000
600/347 V		-	10,000	
DC	Volts 2-Pole	125/250	125/250	
	Interrupting Rating - DC Amperes	14,000	14,000	

## NGG and NGB Circuit Breakers

**Type NGG and NGB circuit breakers** are 125 amp frame breakers that are smaller in size than comparable type ED breakers. NGG breakers come equipped for DIN rail mounting, but alternative mounting hardware is also available.

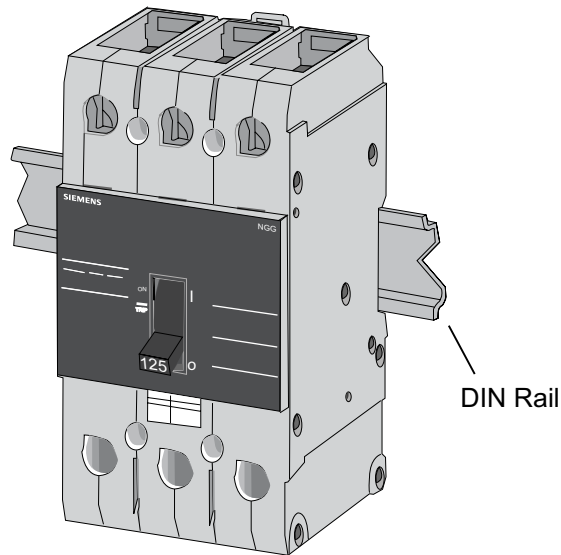

NGG Circuit Breaker

NGB circuit breakers are intended for use as a main circuit breaker in Siemens P1 and P2 panelboards and as a branch circuit breaker in Siemens P1, P2, P3, P4, and P5 panelboards. They are also used in the distribution section of Siemens switchboards replacing ED2 and ED4 circuit breakers.

Interrupting ratings for NGG and NGB circuit breakers depend upon the applied voltage, but, most notably, these breakers have a 65 kA interrupting rating at 240 VAC. Additionally, although NGB breakers carry a 25 kA interrupting rating at 480/277 VAC, they will be applied in Siemens panelboards and switchboards as 22 kA rated for 1 pole and 18 kA rated for 2 and 3 poles. Refer to the SPEEDFAX for IEC interrupting ratings.

		NGG	NGB	
AC	Poles	1, 2, 3	1, 2, 3	
	Amperes, Continuous	1-Pole	15-125	15-125
		2-Pole	15-125	15-125
		3-Pole	15-125	15-125
	Volts (50/60 Hertz)	1-Pole	347	347
		2-Pole	600/347	600/347
		3-Pole	600/347	600/347
	UL Interrupting Rating - Symmetrical RMS Amperes	120 V	65,000	65,000
		240 V	65,000	65,000
		480/277 V	25,000	25,000
600/347 V		14,000	14,000	
DC	Volts 2-Pole	125/250	125/250	
	Interrupting Rating - DC Amperes	14,000	14,000	

## EG and EB Circuit Breakers

**Type EG and EB circuit breakers** are also 125 amp frame breakers that are smaller in size than comparable type ED circuit breakers. These breakers carry an N or H prefix depending upon their interrupting rating (N is normal, H is high). EG circuit breakers can be mounted on a DIN rail with an adapter base or held in place by mounting screws.

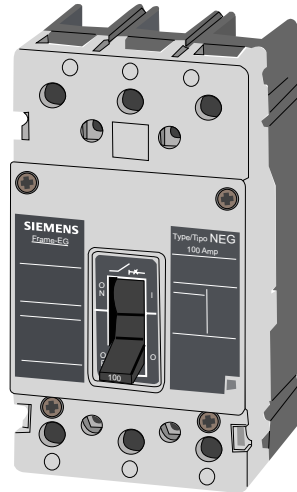

NEG Circuit Breaker

EB circuit breakers are intended for use as a branch circuit breaker in Siemens P3, P4, and P5 panelboards and the distribution section of Siemens switchboards.

		NEG	NEB	HEG	HEB	
AC	Poles	1, 2, 3, 4	1, 2, 3	1, 2, 3, 4	1, 2, 3	
	Amperes, Continuous	1-Pole	15-125	15-125	15-125	15-125
		2-Pole	15-125	15-125	15-125	15-125
		3-Pole	15-125	15-125	15-125	15-125
		4-Pole	15-125	-	15-125	-
	Volts (50/60 Hertz)	1-Pole	347	347	347	347
		2-Pole	600/347	600/347	600/347	600/347
		3-Pole				
		4-Pole				
	UL Interrupting Rating - Symmetrical RMS Amperes	240 V	85,000	85,000	100,000	100,000
480V		35,000	35,000	65,000	65,000	
600/347 V		22,000	22,000	25,000	25,000	
DC	Volts 2-Pole	125/250	125/250	125/250	125/250	
	Interrupting Rating - DC Amperes	35,000	35,000	42,000	42,000	

Refer to the Speedfax for IEC interrupting ratings.

The EG family also includes type HEM motor circuit protectors and type HES molded case switches. HEM motor circuit protectors have continuous current ratings from 3 to 100 amps. HES molded case switches are available in 3-pole or 4-pole versions with continuous current ratings of 100 or 125 amps for 3-pole switches and 125 amps for 4-pole switches.

**ED, FD, JD, LD, LMD, MD, ND, PD, and RD Circuit Breakers**

**Type ED, FD, JD, LD, LMD, MD, ND, PD, and RD thermal-magnetic circuit breakers** provide a range of frame sizes from 125 amp frame ED circuit breakers to 2000 amp frame RD circuit breakers.

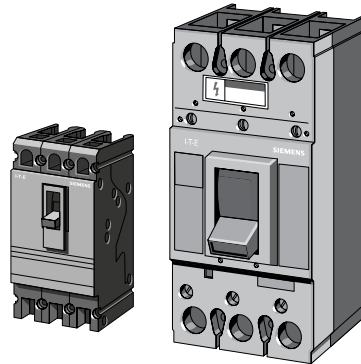

Types ED through LD have variations designated by an H or HH prefix to indicate a higher interrupting rating. Types LMD through RD include the H variation, but not HH. All types, except RD, include a variation with a C prefix to indicate a fuseless current limiting breaker. These designations coincide with label colors. Standard ED, FD, JD, LD, and LMD circuit breakers have a blue label, breakers with H and HH prefixes have a black label, and breakers with a C prefix have a red label.

FD, JD, LD, LMD, MD, ND, PD, and RD circuit breakers, including breakers with H or HH prefixes, are designated as a “complete breaker unassembled with lugs” indicating that they include a frame, interchangeable trip unit, and line-side and load-side lugs in separate packages. For applications requiring non-standard lugs, such as for 75 degree C wire, separate lugs must be ordered.

Where the type designation includes an X or has a C prefix, the breakers are designated as a “complete breaker assembled without lugs” indicating that the breaker has been assembled with a non-interchangeable trip unit and lugs must be ordered separately.

All circuit breakers with the X designation, like the JXD2 and JXD6 breakers, are UL listed for reverse feed applications. This means that power can be applied to the load side of the circuit breaker.

Selected circuit breakers are available as an instantaneous magnetic trip circuit breaker (ETI motor circuit protector) for use in motor circuits where motor overload protection is provided separately. Additionally, a few types are available as a molded case switch (circuit disconnect).

The following charts provide a partial set of ratings for circuit breaker types ED through RD. For additional ratings, including IEC interrupting ratings, refer to the SPEEDFAX.

### ED, FD, JD, LD, and LMD Circuit Breaker Ratings

Circuit Breaker Type		ED2	ED4 <sup>1</sup>	ED6 <sup>2</sup>	HED4 <sup>3</sup>	HHED6	CED6	
Poles		1, 2, 3	1, 2, 3	1, 2, 3	1, 2, 3	2, 3	2, 3	
AC	Amperes, Continuous	15-100	15-125	15-125	15-125	15-125	15-125	
	Volts (50/60 Hertz)	1-Pole	120	277	347	277	-	-
		2, 3-Pole	240	480	600	480	600	600
	UL Interrupting Rating - Symmetrical RMS Amperes	120 V	10,000	-	-	100,000	-	-
		240 V	10,000	65,000	65,000	100,000	100,000	200,000
		277 V	-	22,000	-	65,000	-	-
		347 V	-	-	30,000	-	-	-
480 V		-	18,000	25,000	42,000	65,000	200,000	
600 V	-	-	18,000	-	18,000	100,000		
DC	2-Pole, 250 VDC Interrupting Rating	5,000	30,000	30,000	30,000	-	30,000	
	3-Pole, 500 VDC Interrupting Rating	-	-	18,000	-	-	50,000	

Circuit Breaker Type		FD6A, FXD6A	HFD6, HFXD6	HHFD6, HHFXD6	CFD6	
Poles		2, 3	2, 3	2, 3	2, 3	
AC	Amperes, Continuous	70-250	70-250	70-250	70-250	
	Volts (50/60 Hertz)	2, 3-Pole	600	600	600	600
		240 V	65,000	100,000	200,000	200,000
	UL Interrupting Rating - Symmetrical RMS Amperes	480 V	35,000	65,000	100,000	200,000
600 V		22,000	25,000	25,000	100,000	
DC	2-Pole, 250 VDC Interrupting Rating	30,000	30,000	-	30,000	
	3-Pole, 500 VDC Interrupting Rating	18,000	25,000	-	50,000	

Circuit Breaker Type		JXD2-A	JD6-A, JXD6-A	HJD6-A, HJXD6-A	HHJD6-A, HHJXD6-A	CJD6	
Poles		2, 3	2, 3	2, 3	2, 3	2, 3	
AC	Amperes, Continuous	200-400	200-400	200-400	200-400	200-400	
	Volts (50/60 Hertz)	2, 3-Pole	240	600	600	600	600
		240 V	65,000	65,000	100,000	200,000	200,000
	UL Interrupting Rating - Symmetrical RMS Amperes	480 V	-	35,000	65,000	100,000	150,000
600 V		-	25,000	35,000	50,000	100,000	
DC	2-Pole, 250 VDC Interrupting Rating	30,000	30,000	30,000	-	30,000	
	3-Pole, 500 VDC Interrupting Rating	-	25,000	35,000	-	50,000	

Circuit Breaker Type		LD6, LXD6	HLD6, HLXD6	HHL6, HHLXD6	CLD6	LMD6, LMXD6	HLMD6, HLMXD6	
Poles		2, 3	2, 3	2, 3	2, 3	2, 3	2, 3	
AC	Amperes, Continuous	250-600	250-600	250-600	450-600	500-800	500-800	
	Volts (50/60 Hertz)	2, 3-Pole	600	600	600	600	600	600
		240 V	65,000	100,000	200,000	200,000	65,000	100,000
	UL Interrupting Rating - Symmetrical RMS Amperes	480 V	35,000	65,000	100,000	150,000	50,000	65,000
600 V		25,000	35,000	50,000	100,000	25,000	50,000	
DC	2-Pole, 250 VDC Interrupting Rating	30,000	30,000	-	30,000	30,000	30,000	
	3-Pole, 500 VDC Interrupting Rating	35,000	-	-	50,000	25,000	50,000	

1. ED4 277 V interrupting rating applies to 1-pole breakers.

2. 1-pole ED6 (15-30 A) 30 kA, (35-100 A) 18 kA. CSA Only.

3. HED4 interrupting ratings 35-100 A: 25 kA at 277 VAC, 15-30 A: 65 kA at 277 VAC, 1-pole HED4 15-30A: 65 kA at 240 VAC, 35-100 A: 25 kA at 240 VAC

## MD, ND, PD, and RD Circuit Breaker Ratings

Circuit Breaker Type		MD6, MXD6	HMD6, HMXD6	CMD6	
Poles		2, 3	2, 3	2, 3	
AC	Amperes, Continuous	500-800	500-800	500-800	
	Volts (50/60 Hertz)	2, 3-Pole	600	600	
	UL Interrupting Rating - Symmetrical RMS Amperes	240 V	65,000	100,000	200,000
		480 V	50,000	65,000	100,000
600 V		25,000	50,000	65,000	
DC	2-Pole, 250 VDC Interrupting Rating	30,000	30,000	-	
	3-Pole, 500 VDC Interrupting Rating	25,000	50,000	50,000	
Circuit Breaker Type		ND6, NXD6	HND6, HNXD6	CND6	
Poles		2, 3	2, 3	2, 3	
AC	Amperes, Continuous	800-1200	800-1200	800-1200	
	Volts (50/60 Hertz)	2, 3-Pole	600	600	
	UL Interrupting Rating - Symmetrical RMS Amperes	240 V	65,000	100,000	200,000
		480 V	50,000	65,000	100,000
600 V		25,000	50,000	65,000	
DC	2-Pole, 250 VDC Interrupting Rating	30,000	30,000	-	
	3-Pole, 500 VDC Interrupting Rating	25,000	50,000	50,000	
Circuit Breaker Type		PD6, PXD6	HPD6, HPXD6	CPD6	
Poles		2, 3	2, 3	2, 3	
AC	Amperes, Continuous	1200-1600	1200-1600	1200-1600	
	Volts (50/60 Hertz)	2, 3-Pole	600	600	
	UL Interrupting Rating - Symmetrical RMS Amperes	240 V	65,000	100,000	200,000
		480 V	50,000	65,000	100,000
600 V		25,000	50,000	65,000	
DC	2-Pole, 250 VDC Interrupting Rating	30,000	30,000	30,000	
	3-Pole, 500 VDC Interrupting Rating	25,000	50,000	50,000	
Circuit Breaker Type		RD6, RXD6	HRD6, HRXD6		
Poles		3	3		
AC	Amperes, Continuous	1600-2000	1600-2000		
	Volts (50/60 Hertz)	2, 3-Pole	600	600	
	UL Interrupting Rating - Symmetrical RMS Amperes	240 V	65,000	100,000	
		480 V	50,000	65,000	
600 V		25,000	50,000		
DC	2-Pole, 250 VDC Interrupting Rating	30,000	30,000		
	3-Pole, 500 VDC Interrupting Rating	25,000	50,000		

# Solid-State Trip Unit Circuit Breakers

## **SJD, SLD, SMD, SND, and SPD Circuit Breakers**

Type SJD, SLD, SMD, SND, and SPD circuit breakers are similar to type JD, LD, MD, ND, and PD circuit breakers, but are equipped with a solid-state trip unit. Solid-state trip units make it possible to precisely match overcurrent protection to application requirements.

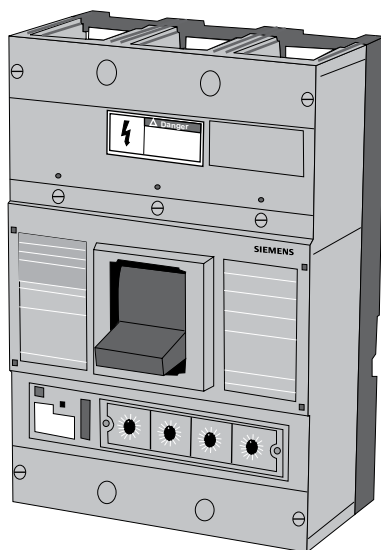

In addition to standard circuit breaker types SJD6, SLD6, SMD6, SND6, and SPD6, which carry a blue label, this family includes high interrupting rating types SHJD6, SHLD6, SHMD6, and SHPD6, which have a black label, and current limiting types SCJD6, SCLD6, SCMD6, and SCND6, which have a red label.

SMD6-H, SHMD6, SCMD6-H, SND6-H, SHND6, and SCND6-H 100% rated breakers are also available.

The following chart provides a partial set of ratings for circuit breaker types SJD6 through SPD6. For additional ratings, including IEC interrupting ratings, refer to the SPEEDFAX.



Circuit Breaker Type		SJD6	SHJD6	SCJD6	SLD6	SHLD6	SCLD6	
Poles		3	3	3	3	3	3	
AC	Amperes, Continuous	200-400	200-400	200-400	300-600	300-600	300-600	
	Volts (50/60 Hertz)	600	600	600	600	600	600	
	UL Interrupting Rating - Symmetrical RMS Amperes	240 V	65,000	100,000	200,000	65,000	100,000	200,000
		480 V	35,000	65,000	150,000	35,000	65,000	150,000
600 V		25,000	35,000	100,000	25,000	35,000	100,000	
Circuit Breaker Type		SMD6	SHMD6	SCMD6	SND6	SHND6	SCND6	
Poles		3	3	3	3	3	3	
AC	Amperes, Continuous	600-800	600-800	600-800	800-1200	800-1200	800-1200	
	Volts (50/60 Hertz)	600	600	600	600	600	600	
	UL Interrupting Rating - Symmetrical RMS Amperes	240 V	65,000	100,000	200,000	65,000	100,000	200,000
		480 V	50,000	65,000	100,000	50,000	65,000	100,000
600 V		25,000	50,000	65,000	25,000	50,000	65,000	
Circuit Breaker Type		SPD6	SHPD6					
Poles		3	3					
AC	Amperes, Continuous	1400-1600	1400-1600					
	Volts (50/60 Hertz)	600	600					
	UL Interrupting Rating - Symmetrical RMS Amperes	240 V	65,000	100,000				
		480 V	50,000	65,000				
600 V		25,000	50,000					

## True RMS Sensing

Some solid state circuit breakers sense the peak values of the current sine wave. This method accurately measures the heating effect of the current when the current sine waves are perfectly sinusoidal. Frequently, however, the sine waves are harmonically distorted by non-linear loads. When this happens, peak current measurement does not adequately evaluate the true heating effect of the current.

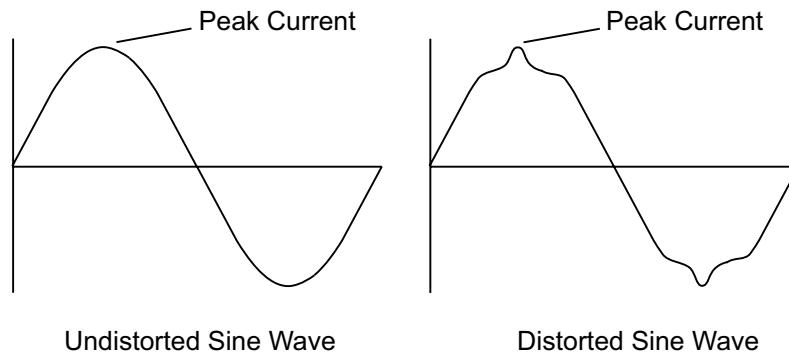

Siemens solid state trip unit circuit breakers incorporate **true root-mean-square (RMS) sensing** to accurately sense the effective value of circuit current. True RMS sensing is accomplished by taking multiple, instantaneous “samples” of the actual current wave shape for a more accurate picture of its true heating value.

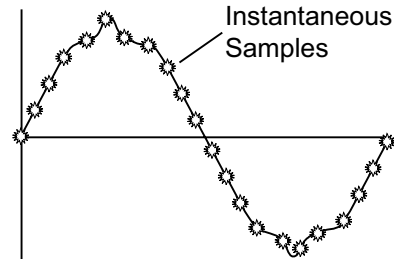

The microcomputer in Siemens solid state trip unit breakers samples the AC current waveform many times a second, converting each value into a digital representation. The microcomputer then uses the samples to calculate the true RMS value of the load current. This capability allows these circuit breakers to perform faster, more efficiently and with repeatable accuracy.

Being able to monitor true RMS current precisely is becoming more important in today's electrical distribution systems because of the increasing number of power electronic devices being used that can distort the current waveform.

## Adjustable Trip Curves

One of the key features of solid state trip unit circuit breakers is the ability to make selective adjustments to the circuit breaker's time-current curve. The time-current curve shown here is for a circuit breaker in the SJD6-SLD6 family.

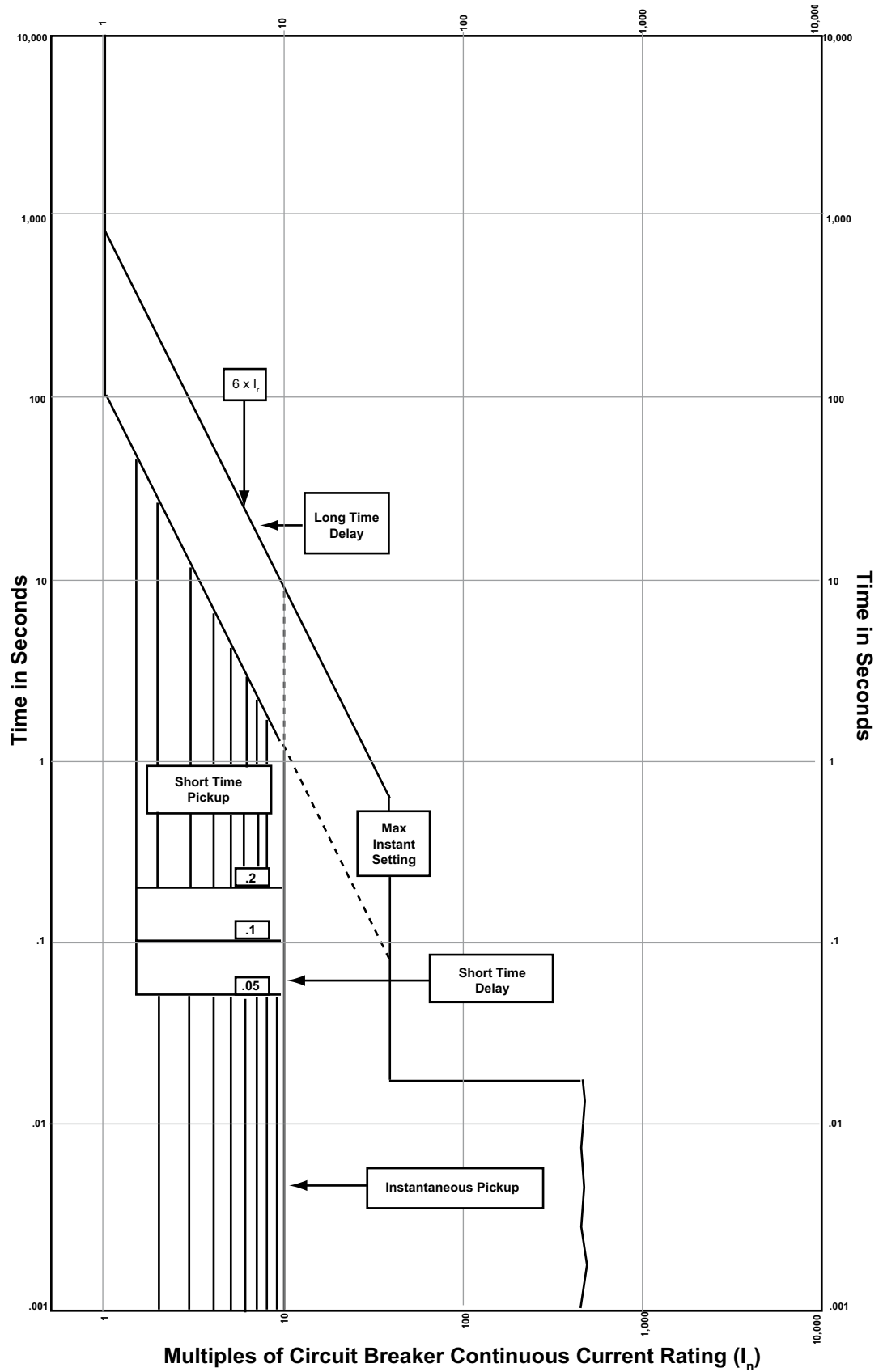

## Solid State Circuit Breaker Adjustments

The type of trip unit included in an SJD6, SLD6, SMD6, SND6, or SPD6 circuit breaker determines the specific time-current curve adjustments available. Breakers in this family may be ordered with any of four trip unit types. Refer to the SPEEDFAX for a listing of the adjustments available with each trip unit type. The following illustration and associated table describes the adjustments available.

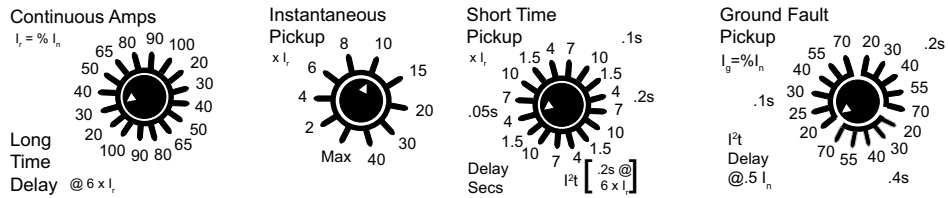

### Circuit Breaker Trip Curve Adjustments

$I_n$ =Nominal Rating of Circuit Breaker

Function	Description
Continuous Ampere ( $I_r$ )	Varies the level of continuous current the circuit breaker will carry without tripping. Adjustable from 20 to 100% of breaker's continuous ampere rating. ( $I_r = \% \text{ of } I_n$ ). Also called long-time pickup.
Long-Time Delay	Referred to as the "overload" position, this function controls the breaker's "pause-in-tripping" time to allow low level or temporary overload currents. Adjustable settings from 3 or 25 seconds at $6 \times I_r$ are possible.
Short-Time Pickup	Controls the amount of high current the breaker will remain closed against for short periods of time, allowing better coordination. Adjustable between 1.5 to 10 times the continuous ampere setting of the circuit breaker (i.e., adjustable from 1.5 to 10 times $I_r$ ).
Short-Time Delay	Controls the amount of time (from .05 to .2 seconds in fixed time, or .2 seconds at $6 \times I_r$ in the $I^2t$ ramp mode) a breaker will remain closed against currents in the pickup range. This function is used in concert with the Short-Time Pickup function to achieve selectivity and coordination. (A pre-determined override automatically preempts the setting at 10.5 times the maximum continuous ampere setting $I_n$ .)
Instantaneous Pickup	Determines the level at which the circuit breaker trips without an intentional time delay. The instantaneous pickup function is adjustable from 2 to 40 times the continuous ampere setting ( $I_r$ ) of the breaker. (Anytime an overlap exists between the instantaneous and short-time pickup settings the instantaneous automatically takes precedence.)
Ground Fault Pickup	Controls level of ground fault current which will cause circuit interruption to occur. Adjustable from 20 to 70 percent of the breaker's maximum continuous ampere setting ( $I_n$ ).
Ground Fault Delay	Adds a predetermined time delay to the trip point once ground fault pickup level is reached. Inverse $I^2t$ ramp is standard which provides better tripping selectivity between the main and feeder or other downstream breakers.

## Review 5

1. Type NGG and NGB circuit breakers are \_\_\_ amp frame breakers that are \_\_\_\_\_ in size than type ED breakers.
2. Which of the following circuit breaker types have a 250 amp frame: CQD, NGG, NGB, NEG, NEB, ED, and FD?
3. Which of the following circuit breaker types has the highest interrupting ratings: NEG, NEB, or HEG?
4. Which of the following circuit breaker types has the largest frame size: ED, FD, JD, LD, or LMD?
5. Which of the following circuit breaker types are fuseless current limiting breakers: FD6A, FXD6A, HFD6, HFXD6, HHFD6, HHFXD6, and CFD6?
6. Which of the following circuit breaker types have a solid-state trip unit: LD6, LMD6, SLD6, and SHLD6?

# Internal Accessories

An accessory is an addition that adds to the performance of a circuit breaker or adapts the circuit breaker for specific application requirements. This section provides examples of **internal accessories**, accessories that incorporate internal components, used by some of the circuit breakers discussed thus far in this course. Four common internal accessories are shunt trip, undervoltage trip, auxiliary switches, and bell alarm.

## ED Frame Accessories

Mounting of internal accessories is handled differently for ED frame circuit breakers than for the other Siemens thermal-magnetic circuit breakers. ED frame circuit breaker internal accessories are mounted on the side of the circuit breaker as shown in the following illustration.

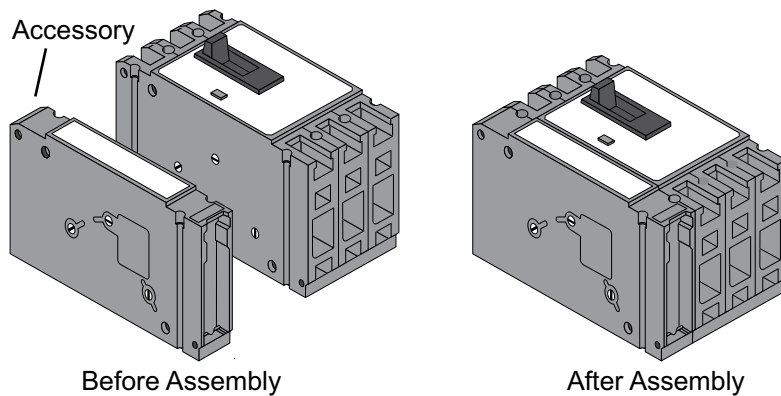

## FD, JD, LD, LMD, MD, ND, PD, and RD Frame Internal Accessories

To mount internal accessories in FD, JD, LD, and LMD frame circuit breakers, remove the cover and install the accessories as shown in the following illustrations.

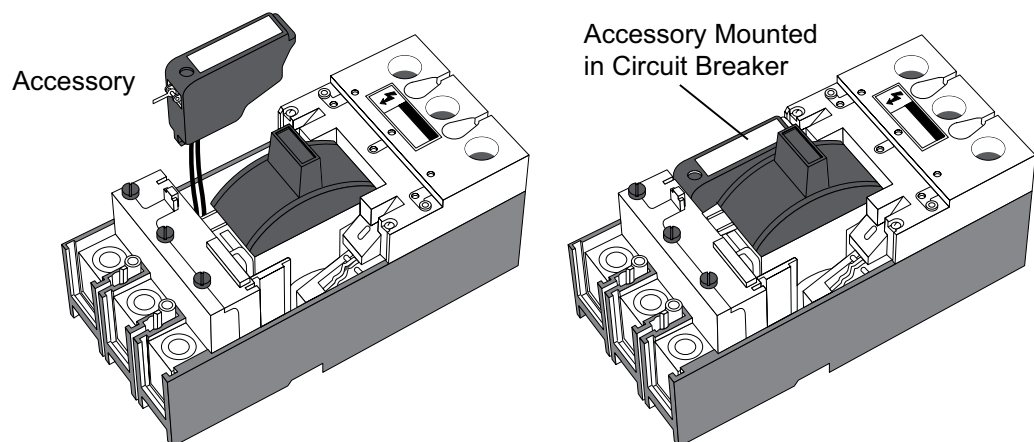

## Shunt Trip

Because circuit breakers are often in a location far from operating equipment, it is sometimes necessary to trip a breaker remotely so that equipment can be stopped rapidly. For this reason, a circuit breaker **shunt trip** device is sometimes wired to a push button located on or near an operator panel.

The shunt trip device consists of a coil in series with a limit switch. When the circuit breaker main contacts are closed, the limit switch is closed. Pressing a customer-supplied pushbutton energizes the shunt trip coil, which causes the breaker's mechanical latch to disengage the trip mechanism and open the circuit breaker's contacts. When the circuit breaker's contacts open, the limit switch also opens, removing power from the shunt trip coil. As with any trip, the breaker must be reset manually.

Common voltages for the shunt trip coil are 24 VDC, 48 VDC, 125 VDC, 120 VAC, 240 VAC, and 480 VAC.

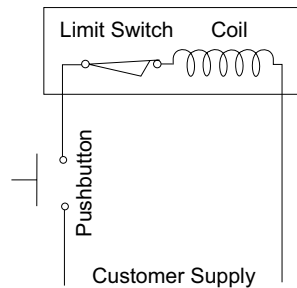

## Undervoltage Trip

The **undervoltage trip** device is designed to automatically trip the circuit breaker when the supply voltage drops to a low value (35-70% of nominal line voltage). The device also prevents the circuit breaker from being reclosed until the supply voltage returns to at least 85% of its normal level.

Common voltages for the undervoltage trip coil are 24 VDC, 48 VDC, 125 VDC, 120 VAC, 240 VAC, and 480 VAC.

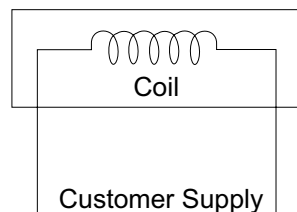

## Auxiliary Switch

An **auxiliary switch** is an accessory that can be wired to a circuit that indicates the position of the circuit breaker main contacts. For example, in the circuits shown below, contact "A" is closed and the indicator light is on when the circuit breaker is on. At the same time, contact B is open. If the circuit breaker is tripped or turned off, the states of the auxiliary switch contacts change and the light goes out.

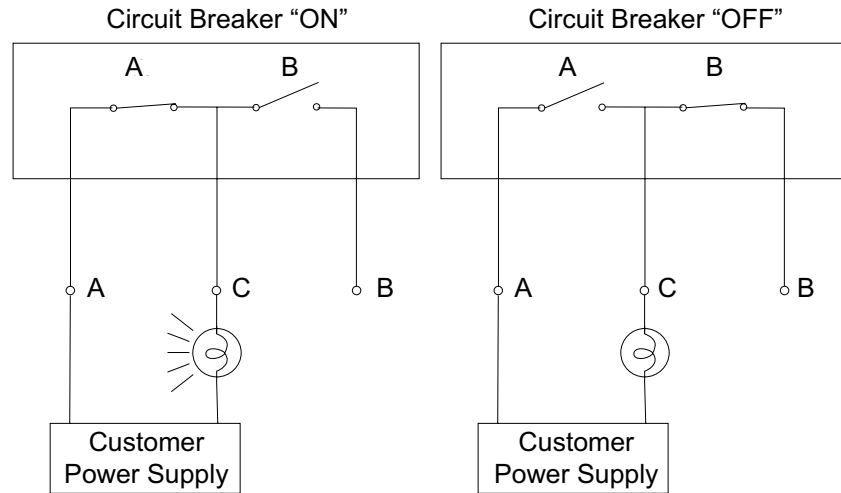

## Bell Alarm Switch

The **bell alarm** switch differs from the auxiliary switch in that it only functions when the circuit breaker trips. Opening and closing the circuit breaker by means of the operating handle does not affect the position of the bell alarm switch contacts. The "A" contact closes and the "B" contact opens when the circuit breaker trips. A horn or indicator light can be used to indicate the circuit breaker has tripped.

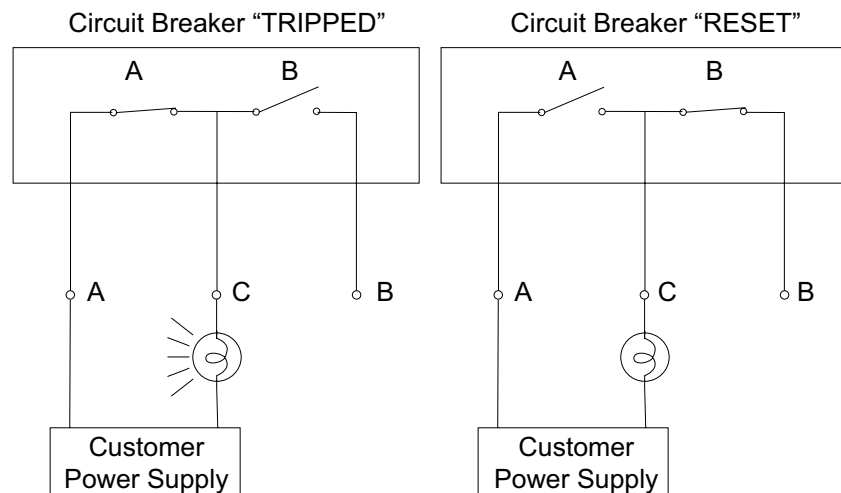



# External Accessories

External accessories make circuit breakers suitable for specific applications. A variety of external accessories are available. This section describes examples of external accessories available for some of the types of circuit breakers previously discussed in this course.

### Rear Connecting Studs

**Rear connecting studs** are used for switchboard mounting of circuit breakers. Rear connecting studs are available in various lengths of either bus or cable connections.

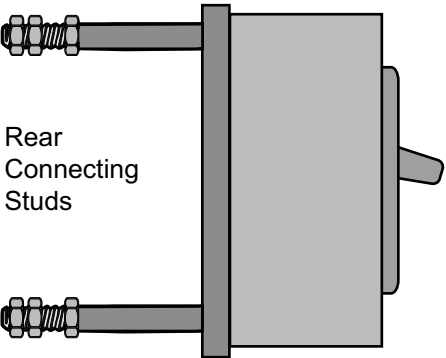

### Rocker Arm Assembly

The **rocker arm assembly** is used to mechanically interlock two adjacent circuit breakers of the same frame configuration. Both circuit breakers can be open at the same time, but the assembly allows only one breaker to be closed at any time.

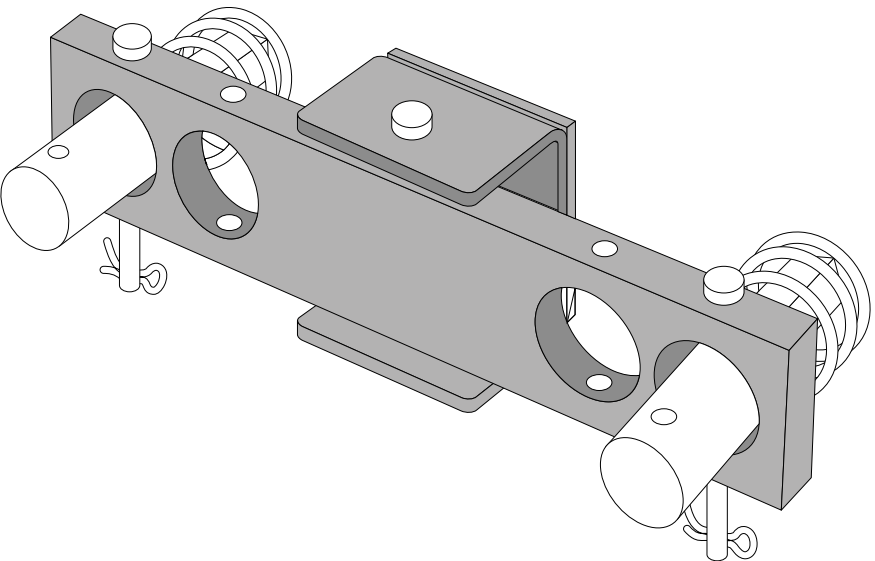

## Max-Flex Handle Operator

**Max-Flex flange-mount handle operator** is a flexible cable control device used for remote switching of a circuit breaker within an enclosure.

The flexible cable is connected directly to the breaker switch handle at one end and a factory installed handle operator at the other end. The remote handle operator located on the enclosure is used to perform mechanical open/close switching operations.

The cable comes in standard 3 or 4 foot lengths, however, lengths up to 20 feet can be ordered. When using a standard circuit breaker handle extension, it is necessary to align the breaker exactly with the extension. With the Max-Flex handle operator, this exact alignment is not necessary.

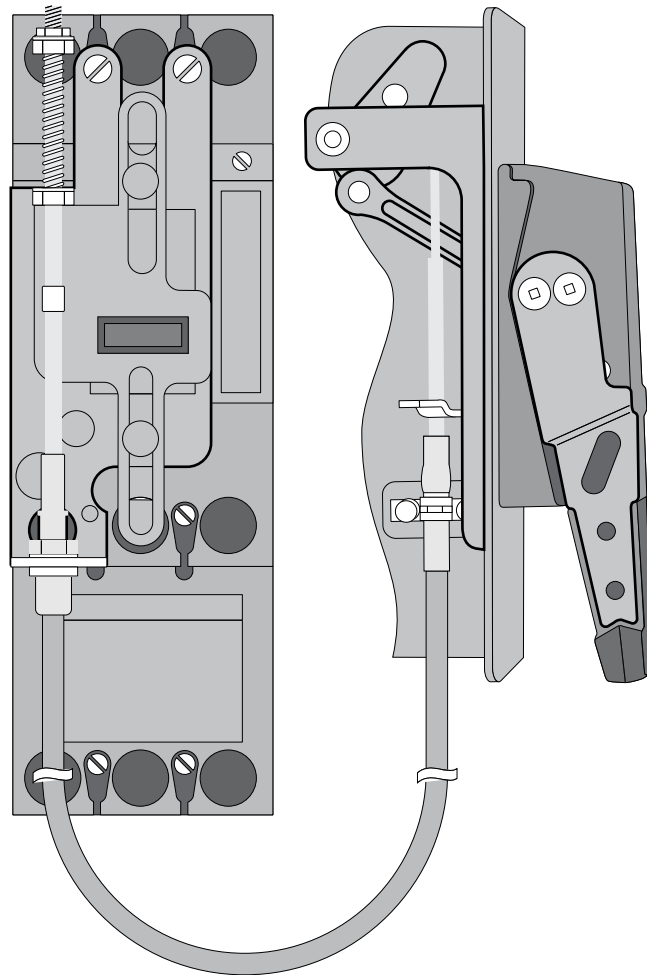

## Electric Motor Operator

The **Telemand electric motor operator** is designed to open, close, and reset a circuit breaker by remote control. It is mounted on the face of the circuit breaker so that it can engage the breaker's operating handle. The built-in motor is connected to remote pushbuttons or contacts. Pressing the "ON" pushbutton or closing the "ON" contacts causes the electric motor to move the circuit breaker to the "ON" position. Pressing the "OFF" pushbutton or closing the "OFF" contacts causes the electric motor to move the circuit breaker to the "OFF" position. To reset the circuit breaker from the tripped position, the electric motor must first move the circuit breaker handle to the "OFF" position and then to the "ON" position, just as it is performed manually.

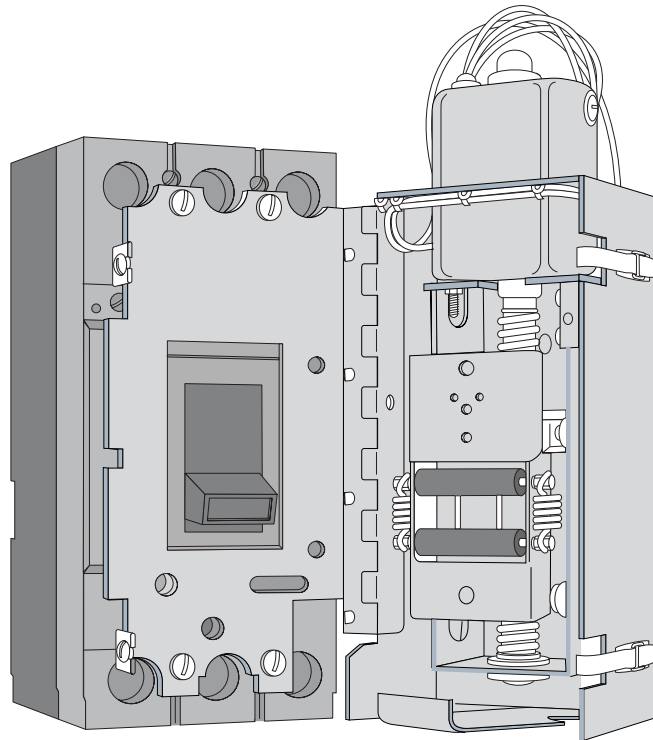

## Terminal Connectors

Various **terminal connectors** are available to permit easy front connection of either copper or aluminum insulated conductors to the terminal of a circuit breaker or molded case switch.

For low amperage and low vibration applications, mechanical lugs are suitable. For high amperage or high vibration applications, compression lugs are needed to provide secure, low resistance connections.

Terminal connectors are designed and tested to accommodate the conductors or requirements outlined within the related UL and NEC® standards.

#### Mechanical Lug Connection

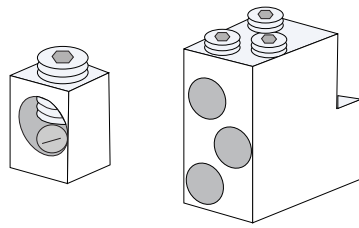

Cable Stripped for Mechanical Lug Connection

#### Compression Lug Connection

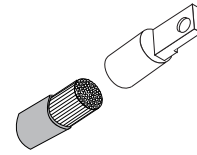

Compression Lug Connector is Crimped onto Cable

### Plug-In Assemblies

**Plug-in mounting assemblies** provide a means for a quick change out of circuit breakers and molded case switches without disturbing the power connections.

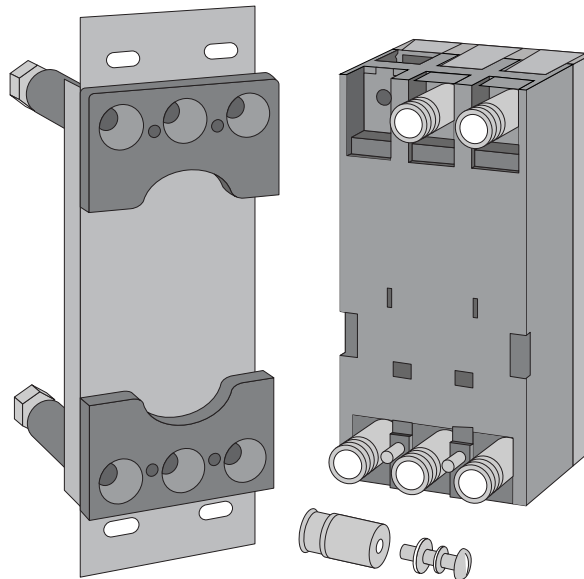

## Handle Blocking Device

A **handle blocking device** is a non-lockable device that may be added to a circuit breaker to secure the handle in either the "ON" or "OFF" position. The device slides into slots provided on the circuit breaker. This device prevents accidental operation of the handle. Since Siemens Sentron breakers have a "trip-free" design, the device will not prevent the circuit breaker from tripping when blocked in the "ON" position. The following illustration shows the handle blocked in the "ON" position.

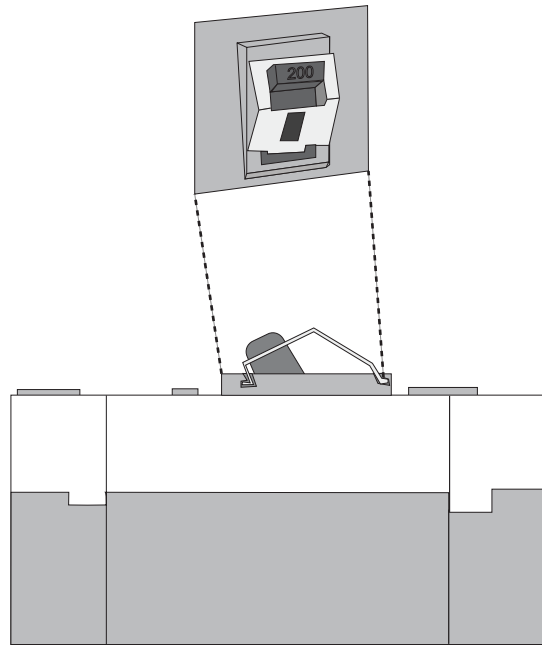

## Handle Padlocking Device

The **handle padlocking device** is used to padlock the circuit breaker in the "ON" or "OFF" position. The device mounts over the handle and a customer supplied padlock is used to lock the handle. The breaker will still trip if locked in the "ON" position.

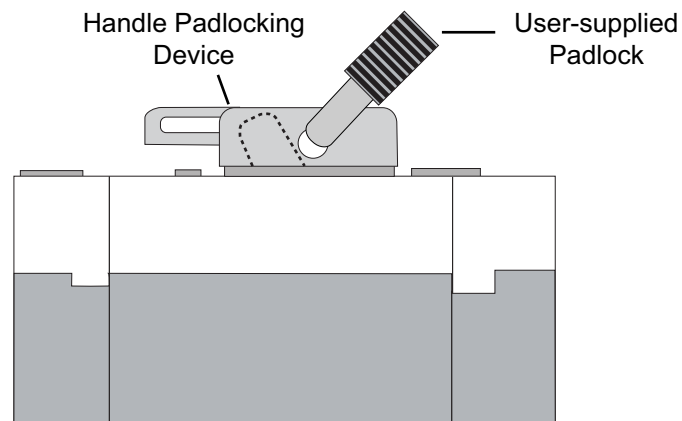

## Ground Fault Sensor

An **external ground fault sensor** is available for the ED frame circuit breakers. The relay functions to de-energize a circuit within an established period of time when the current to ground exceeds a predetermined value. This is done by sensing the difference between two or more load conductors passing through the sensor. A  $5 \text{ mA} \pm 1 \text{ mA}$  current difference (for circuits requiring personnel protection) or a  $30 \text{ mA} \pm 6 \text{ mA}$  current difference (for circuits requiring only equipment protection) is the threshold for a ground fault.

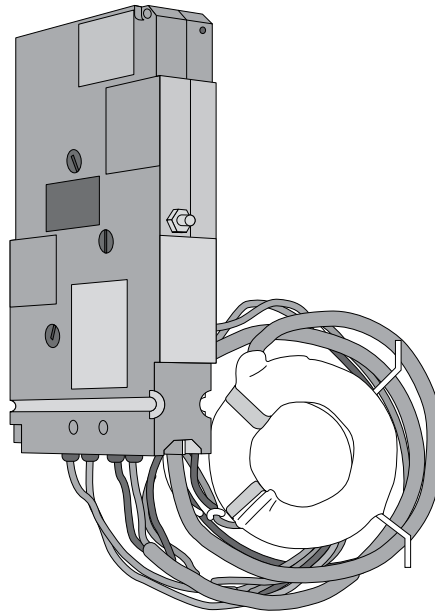

## Review 6

1. A \_\_\_\_\_ - \_\_\_\_\_ option is used when it is necessary to trip a breaker from a remote location, but cannot be used to reset the breaker.
2. An \_\_\_\_\_ device is used to automatically trip a circuit breaker when the supply voltage drops.
3. The advantage of the Max-Flex flange-mount handle operator versus a handle extender is that \_\_\_\_\_ isn't necessary.
4. The \_\_\_\_\_ is used to prevent two adjacent circuit breakers from being closed at the same time.
5. \_\_\_\_\_ - \_\_\_\_\_ mounting assemblies provide a means for a quick change out of circuit breakers without disturbing the power connections.

# VL Circuit Breakers

**Siemens VL family of circuit breakers** incorporates a compact, modular design that allows these breakers to be configured to match a wide range of application specifications. Additionally, VL circuit breakers have been engineered to meet global requirements and carry the following markings.

Marking	Relevant Standard
UL	UL 489
CSA	CSA-C22.2
NOM	NMX-J-266-ANCE-2002
CE	IEC 60947-2

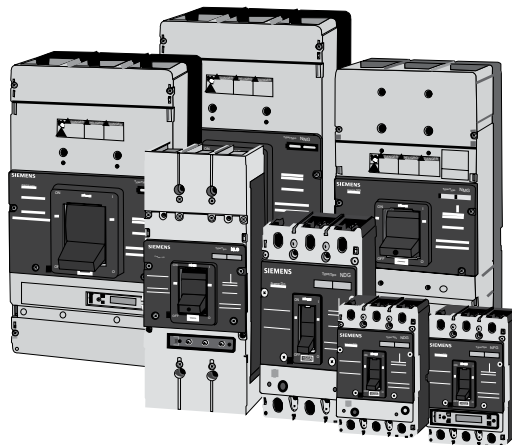

The VL family includes frame sizes from 150 to 1600 amps. The following three interrupting rating classes are available for each circuit breaker frame.

- N - Normal
- H - High
- L - Very High

One of the many aspects of the VL circuit breaker family is the flexibility of each VL circuit breaker frame to accommodate any of the following three available trip units.

- Model 525 Thermal-Magnetic Trip Unit
- Model 545 Electronic Trip Unit
- Model 576 Electronic Trip Unit with LCD Display

The VL family also includes molded case switches, motor circuit protectors, and other complete breakers with non-interchangeable trip units.

Internal accessories for VL circuit breakers are field-installable and are conveniently located in pockets behind the front accessory cover. To simplify the selection of accessories, just two groups of internal accessories cover the entire VL family.

Additional external accessories are also available to accommodate a wide variety of application requirements for connecting, mounting, and operating VL circuit breakers.

Communication modules are available for connecting to Modbus or Profibus systems.

The following illustration identifies the array of trip units, options, and accessories for use with VL circuit breakers.

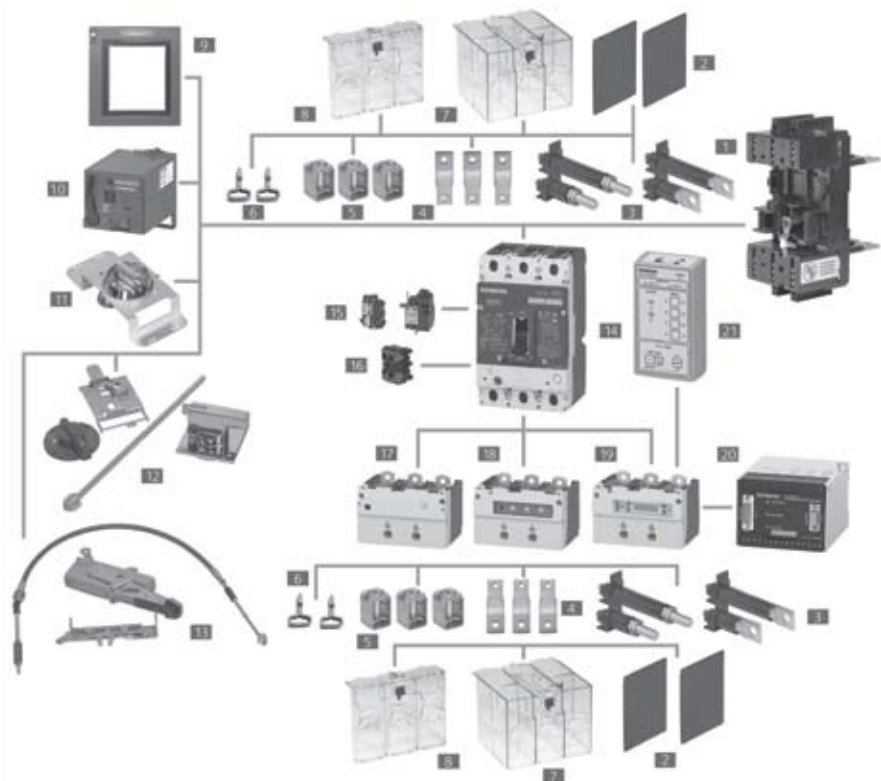

- |                                    |   |
|------------------------------------|---|
| 1. Base for Plug-in or Draw-out    | 12. Variable Depth Rotary Operator      |
| 2. Interphase Barriers             | 13. Max Flex Operator                   |
| 3. Rear Terminals - Flat and Round | 14. Circuit Breaker                     |
| 4. Bus Extensions                  | 15. Shunt Trip or Undervoltage Release  |
| 5. Terminal Connectors             | 16. Auxiliary/Alarm Switches            |
| 6. Plug-in Terminal Blades         | 17. Thermal-Magnetic Trip Unit (525)    |
| 7. Extended Terminal Shield        | 18. Electronic Trip Unit (545)          |
| 8. Standard Terminal shield        | 19. Electronic Trip Unit with LCD (576) |
| 9. Cover Frame for Door Cutout     | 20. Communication Module with ZSI       |
| 10. Stored Energy Operator         | 21. Electronic Trip Unit Test Kit       |
| 11. Rotary Handle Operator         |   |



Breaker Type	NDG	HDG	LDG	NFG	HFG	LFG	NJG	HJG	LJG	NLG	HLG	LLG
Poles	2,3,4			2,3,4			2,3,4			2,3		
Continuous Ampere Range	30-150			40-250			70-400			150-600		
Max. Volts (50/60 Hertz)	600			600			600			600		
UL, 240 VAC Interrupting Rating (Symmetrical RMS Amperes)	65,000	100,000	200,000	65,000	100,000	200,000	65,000	100,000	200,000	65,000	100,000	200,000
UL, 480 VAC Interrupting Rating (Symmetrical RMS Amperes)	35,000	65,000	100,000	35,000	65,000	100,000	35,000	65,000	100,000	35,000	65,000	100,000
UL, 600 VAC Interrupting Rating (Symmetrical RMS Amperes)	18,000	20,000	25,000	18,000	20,000	25,000	25,000	25,000	25,000	25,000	25,000	25,000
UL, 2-Pole, 250 VDC Interrupting Rating (Amperes)	30,000	30,000	30,000	30,000	30,000	30,000	30,000	30,000	30,000	30,000	30,000	30,000
UL, 3-Pole, 500 VDC Interrupting Rating (Amperes)	18,000	18,000	18,000	18,000	18,000	30,000	25,000	35,000	35,000	25,000	35,000	35,000
Trip Unit Options												
Thermal-Magnetic	•			•			•			•		
Electronic	•			•			•			•		
Electronic with LCD	•			•			•			•		
Reverse Feed (w/Non-Interchangeable Trip)	•			•			•			•		
Communication Capability <sup>1</sup>	•			•			•			•		
Specific Application Breakers												
Molded Case Switch	•			•			•			•		
Motor Circuit Protector	•			•			•			•		
100% Rated	•			•			•			•		
50° C Calibrated <sup>2</sup>	•			•			•			•		
Accessories and Modifications												
Auxiliary Switch	•			•			•			•		
Alarm Switch	•			•			•			•		
Shunt Trip	•			•			•			•		
Undervoltage Release	•			•			•			•		
Mechanical Interlocks	•			•			•			•		
Elect. Motor or Stored Energy Operator	•			•			•			•		
Rear Connecting Studs	•			•			•			•		
Plug-in Mounting Assy. w/ trip interlock	•			•			•			•		
Draw-out Assembly	•			•			•			•		
Handle Mechanisms	•			•			•			•		
Enclosures												
NEMA 1 (Indoor, Surface Mount)	•			•			•			•		
NEMA 1 (Indoor, Flush Mount)	•			•			•			•		
NEMA 3R (Outdoor, Rain Proof)	•			•			•			•		
NEMA 4,4X (Stainless Steel)	•			•			•			•		
NEMA 7,9 (Hazardous Locations)	•			•			•			•		
NEMA 12 (Lint, Fine Dust, Oils, Coolant)	•			•			•			•		
Additional Items												
Thermal Shields	•			•			•			•		
Distribution Lugs	•			•			•			•		
Ground Sensor (Neutral Transformer)	•			•			•			•		

1. Communication modules available for Profibus protocol.

2. Check for availability.

3. IEC ratings available online.

Breaker Type	NMG	HMG	LMG	NNG	HNG	LNG	NPG	HPG	LPG
Poles	2,3,4			2,3,4			3,4		
Continuous Ampere Range	200-800			300-1200			400-1600		
Max. Volts (50/60 Hertz)	600			600			600		
UL, 240 VAC Interrupting Rating (Symmetrical RMS Amperes)	65,000	100,000	200,000	65,000	100,000	200,000	65,000	100,000	200,000
UL, 480 VAC Interrupting Rating (Symmetrical RMS Amperes)	35,000	65,000	100,000	35,000	65,000	100,000	35,000	65,000	100,000
UL, 600 VAC Interrupting Rating (Symmetrical RMS Amperes)	25,000	35,000	50,000	25,000	35,000	65,000	25,000	35,000	65,000
UL, 2-Pole, 250 VDC Interrupting Rating (Amperes)	22,000	25,000	42,000	22,000	25,000	42,000	22,000	25,000	42,000
UL, 3-Pole, 500 VDC Interrupting Rating (Amperes)	35,000	50,000	65,000	35,000	50,000	65,000	35,000	50,000	65,000
<b>Trip Unit Options</b>									
Thermal-Magnetic	•			•			•		
Electronic	•			•			•		
Electronic with LCD	•			•			•		
Reverse Feed (w/Non-Interchangeable Trip)	•			•			•		
Communication Capability <sup>1</sup>	•			•			•		
<b>Specific Application Breakers</b>									
Molded Case Switch	•			•			•		
Motor Circuit Protector	•			•			•		
100% Rated	•			•			•		
50° C Calibrated <sup>2</sup>	•			•			•		
<b>Accessories and Modifications</b>									
Auxiliary Switch	•			•			•		
Alarm Switch	•			•			•		
Shunt Trip	•			•			•		
Undervoltage Release	•			•			•		
Mechanical Interlocks	•			•			•		
Elect. Motor or Stored Energy Operator	•			•			•		
Rear Connecting Studs	•			•			•		
Plug-in Mounting Assembly with trip interlock	•			•			•		
Draw-out Assembly	•			•			•		
Handle Mechanisms	•			•			•		
<b>Enclosures</b>									
NEMA 1 (Indoor, Surface Mount)	•			•			•		
NEMA 1 (Indoor, Flush Mount)	•			•			•		
NEMA 3R (Outdoor, Rain Proof)	•			•			•		
NEMA 4,4X (Stainless Steel)	•			•			•		
NEMA 7,9 (Hazardous Locations)	•			•			•		
NEMA 12 (Lint, Fine Dust, Oils, Coolant)	•			•			•		
<b>Additional Items</b>									
Thermal Shields	•			•			•		
Distribution Lugs	•			•			•		
Ground Sensor (Neutral Transformer)	•			•			•		

1. Communications modules available for Profibus or Modbus protocol.

2. Check for availability.

3. IEC ratings available online.

## Model 525 Trip Units

As previously mentioned, three trip unit models, 525, 545, and 576, are available for each VL circuit breaker type. **Model 525 Thermal-Magnetic Trip Units** are available with multiple continuous current ratings. For example, MG frame circuit breakers can be equipped with a 600 A, 700 A, or 800 A Model 525 trip unit. The time current curve below is for an 800 A Model 525 trip unit. Note that while the continuous current rating is set by the selection of the trip unit, the instantaneous pickup setting ( $I_i$ ), is adjustable.

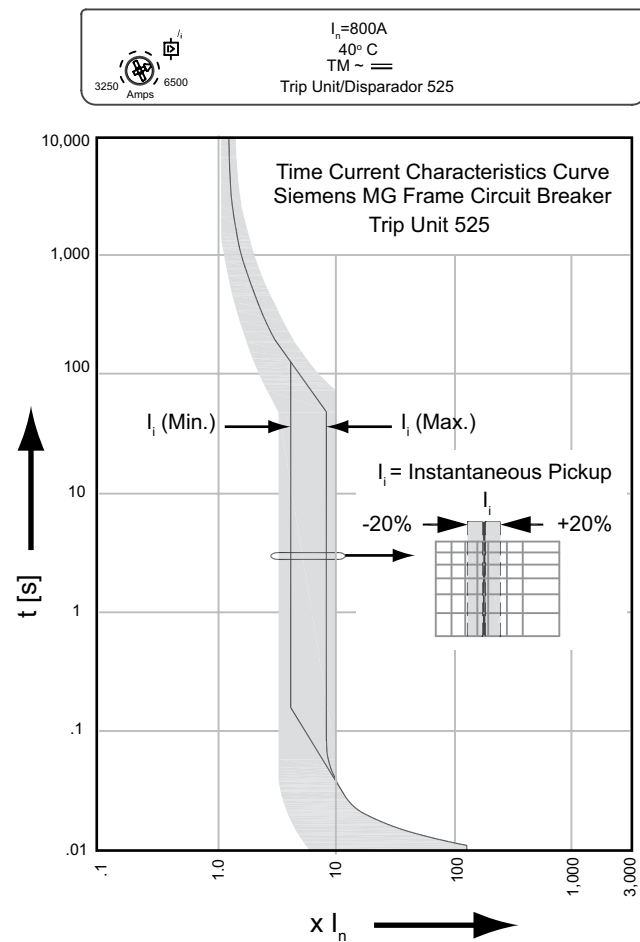

## Model 545 Trip Units

**Model 545 Electronic Trip Units** allow the user to adjust the circuit breaker's time current curve to provide optimal protection and avoid nuisance tripping. Model 545 trip units are available with multiple maximum continuous current ratings. For example, MG frame circuit breakers can be equipped with a 600 A or 800 A Model 545 trip unit.

Which protective functions are provided by a Model 545 trip unit is dependent upon the trip unit version. Model 545 trip units may be ordered with LI, LSI, LIG, or LSIG functions.

The letter designations used to identify these functions are based upon a recognized international standard (IEC 60947-2, Appendix K) and can be described as follows:

- L = long time pickup and delay = overload protection
- S = short time pickup and delay = short circuit protection (short-time delayed)
- I = instantaneous = short-circuit protection (instantaneous)
- G = ground fault pickup and delay = ground fault protection

The characteristics of a time current curve for a VL circuit breaker with a Model 545 trip unit will depend upon the specific trip unit selected and whether the I<sup>2</sup>T function is turned on. The time current curve shown below identifies important time-current characteristics for an 800 A Model 545 trip unit with LSI protection and I<sup>2</sup>T turned on.

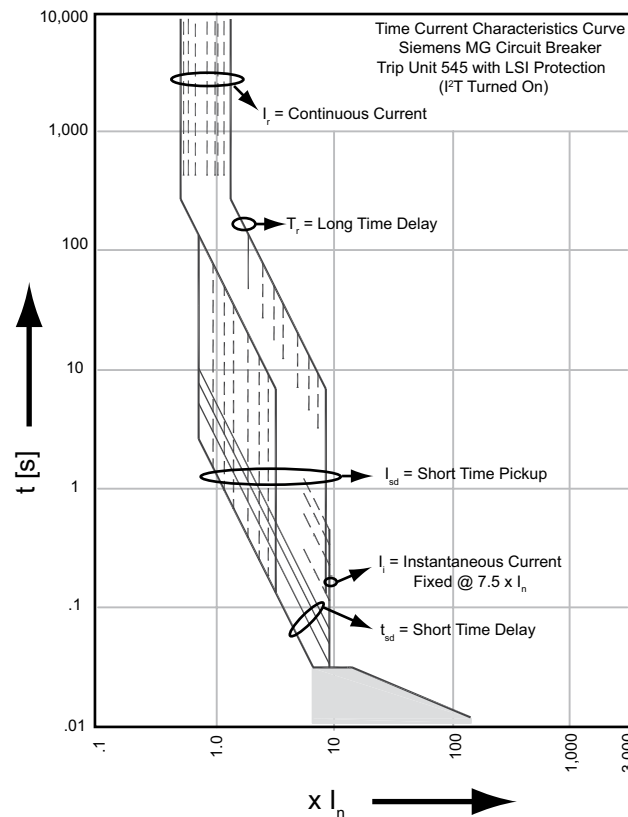
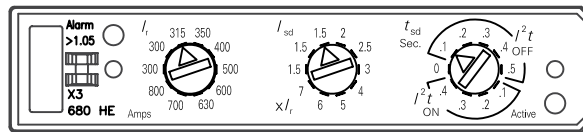

## Model 576 Trip Units

**Model 576 Electronic Trip Units with LCD** also allow the user to adjust the circuit breaker's time current curve to provide optimal protection and avoid nuisance tripping. The Liquid Crystal Display (LCD) provides a user-friendly, menu driven method for setting protection parameters and continuously shows the current for each phase.

Model 576 trip units are available with multiple maximum continuous current ratings. For example, MG frame circuit breakers can be equipped with a 600 A or 800 A Model 576 trip unit. Model 576 trip units are equipped with LSI or LSI<sup>2</sup> protective functions.

The characteristics of a time current curve for a VL circuit breaker with a Model 576 trip unit will depend upon the specific trip unit selected and whether the I<sup>2</sup>T function is turned on. The time current curve shown below identifies important time-current characteristics for an 800 A Model 576 trip unit with LSI protection and I<sup>2</sup>T turned on.

The Model 576 is the only trip unit which permits communication with the Modbus or Profibus communication module.

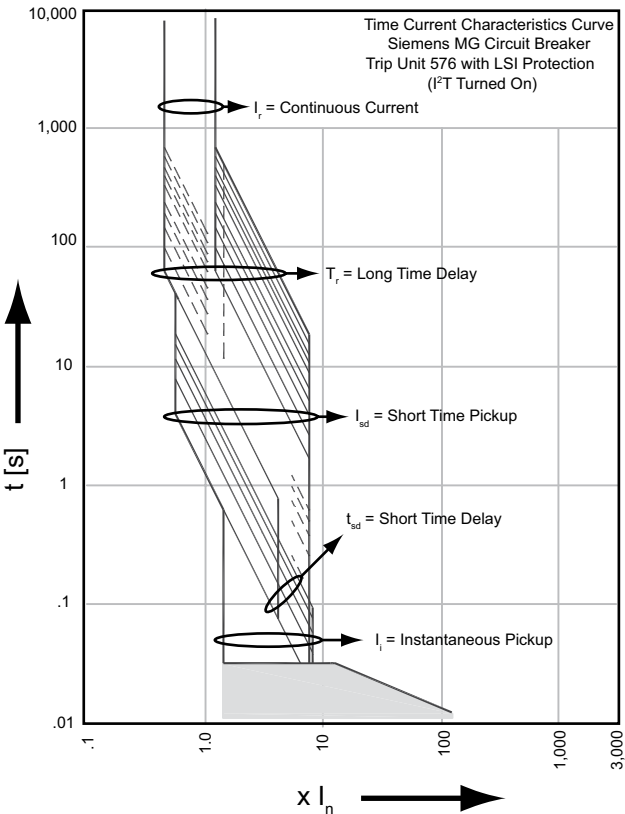
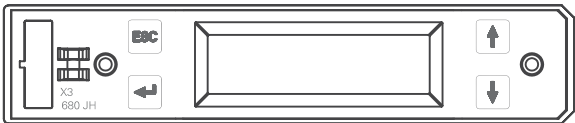

## Review 7

1. Siemens VL circuit breakers are engineered to meet global requirements and carry the following markings: \_\_\_\_\_, \_\_\_\_\_, \_\_\_\_\_, and \_\_\_\_\_.
2. The following interrupting rating classes are available for VL Breakers: \_\_\_\_\_, \_\_\_\_\_, and \_\_\_\_\_.
3. Which of the following trip units is a thermal-magnet trip unit: Model 525, Model 545, or Model 576?
4. Which of the following VL breaker frame sizes has a continuous current ( $I_r$ ) range from 120 to 1600 amperes: MG, NG, or PG?
5. Which of the following letter designations is used to indicate that a trip unit provide overload protection: L, S, I, or G?

# WL Circuit Breakers

**Siemens WL family of circuit breakers** has been designed to address the increasingly demanding requirements of today's electrical power distribution systems and incorporates the following characteristics.

- High reliability
- Compact size
- Ease of use
- Modularity of design
- Flexibility of system communications
- Safety-oriented features

The circuit breakers discussed thus far in this course are molded case circuit breakers that conform to the UL 489 specification. This specification also covers a category of molded case circuit breaker commonly referred to as an **insulated case circuit breaker (ICCB)**. ICCBs are generally used in switchboards and may be fixed mounted or drawout mounted.

Another category of large circuit breakers is the **low voltage (LV) power circuit breaker**. LV power circuit breakers are generally drawout mounted and may be used in switchboards or switchgear. LV power circuit breakers intended for the U.S. market conform to American National Standards Institute (ANSI) standards (C37.13, C37.16, C37.17, and C37.50) and National Electrical Manufacturers Association (NEMA) standard SG3. The corresponding UL specification for LV power circuit breakers is UL 1066.

Siemens WL family of circuit breakers includes both ICCBs that conform to the UL 489 specification and LV power circuit breakers that conform to UL 1066 and corresponding ANSI and NEMA specifications.

## Modularity of Design

As previously mentioned, one of the important characteristics of the WL family of circuit breakers is its modularity of design. The following illustration identifies the array of trip units, options, and accessories for use with WL circuit breakers.

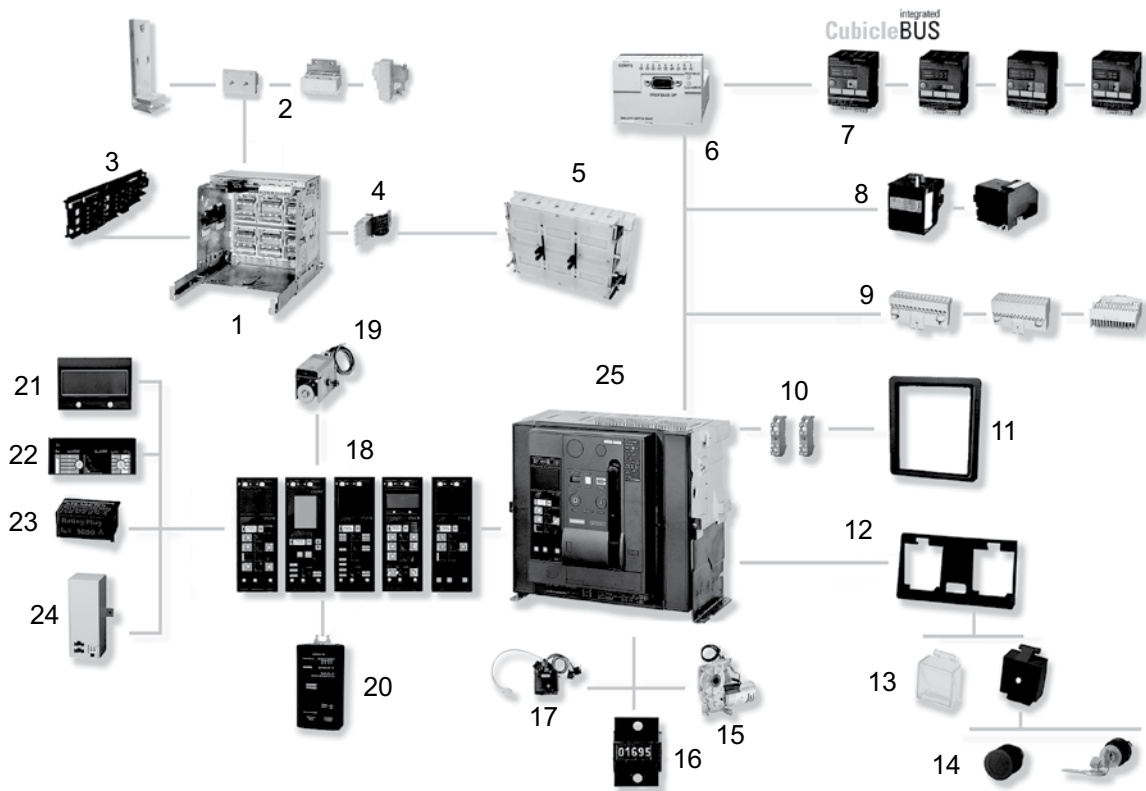

- |   |   |
|---|---|
| 1. Guide Frame (for drawout version)        | 14. Emergency-Stop Pushbutton, Key Operated |
| 2. Vertical to Horizontal BUS Connector     | 15. Single Bolt Motor Operator Installation |
| 3. Position Signaling Switch                | 16. Operating Cycles Counter                |
| 4. Breaker/Guide Frame Grounding Contact    | 17. Breaker Status Sensor (BSS)             |
| 5. Shutter (locking)                        | 18. Electronic Trip Unit (ETU) Family       |
| 6. Modbus or Profibus Communications        | 19. Reset Solenoid                          |
| 7. External CubicleBUS I/O Module           | 20. Breaker Data Adapter (BDA)              |
| 8. Plug-in Open and Closed Solenoids        | 21. Four-line LCD Module                    |
| 9. Multiple Secondary Connections           | 22. Ground-fault Function Module            |
| 10. Auxiliary Switch Block                  | 23. Rating Plug                             |
| 11. Door Sealing Frame                      | 24. Metering Function Module                |
| 12. Interlocking Set Base Plate             | 25. Circuit Breaker                         |
| 13. Protective Cover for OPEN/CLOSE Buttons |   |



**WL UL 489 Circuit Breakers** WL UL 489 circuit breakers have a rated maximum operating voltage of 600 V and are available in three frame sizes with frame ratings from 800 to 5000 A. All three frame sizes have fixed-mounted and drawout-mounted versions.

Frame Size I

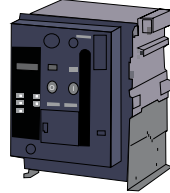

Frame Size II

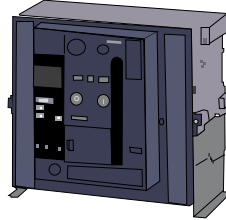

Frame Size III

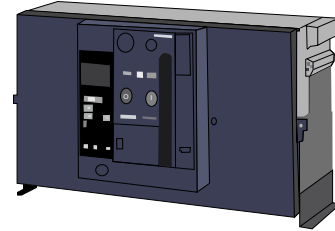

Frame Size I									
Rated Nominal Current	800 A			1200 A					
Rating Class	S	H	L	S	H	L			
Interrupting Current ( $I_{cs}$ ) at 240 V	65,000	85,000	100,000	65,000	85,000	100,000			
Interrupting Current ( $I_{cs}$ ) at 480 V	65,000	85,000	100,000	65,000	85,000	100,000			
Interrupting Current ( $I_{cs}$ ) at 600 V	65,000	65,000	65,000	65,000	65,000	65,000			
Frame Size II									
Rated Nominal Current	800 A			1200 A			1600 A		
Rating Class	S	L	C	S	L	C	S	L	C
Interrupting Current ( $I_{cs}$ ) at 240 V	65,000	100,000	150,000	65,000	100,000	150,000	65,000	100,000	150,000
Interrupting Current ( $I_{cs}$ ) at 480 V	65,000	100,000	150,000	65,000	100,000	150,000	65,000	100,000	150,000
Interrupting Current ( $I_{cs}$ ) at 600 V	65,000	85,000	100,000	65,000	85,000	100,000	65,000	85,000	100,000
Frame Size II									
Rated Nominal Current	2000 A			2500 A		3000 A			
Rating Class	S	L	C	L	C	L	C		
Interrupting Current ( $I_{cs}$ ) at 240 V	65,000	100,000	150,000	100,000	150,000	100,000	150,000		
Interrupting Current ( $I_{cs}$ ) at 480 V	65,000	100,000	150,000	100,000	150,000	100,000	150,000		
Interrupting Current ( $I_{cs}$ ) at 600 V	65,000	85,000	100,000	85,000	100,000	85,000	100,000		
Frame Size III									
Rated Nominal Current	4000 A		5000 A						
Rating Class	L	C	L	C					
Interrupting Current ( $I_{cs}$ ) at 240 V	100,000	150,000	100,000	150,000					
Interrupting Current ( $I_{cs}$ ) at 480 V	100,000	150,000	100,000	150,000					
Interrupting Current ( $I_{cs}$ ) at 600 V	85,000	100,000	85,000	100,000					

1. Interrupting Current in Symmetrical RMS Amperes

**WL UL 1066 Circuit Breakers** WL UL 1066 circuit breakers are generally used in low voltage (LV) switchgear as drawout-mounted breakers, have a rated maximum operating voltage of 635 V, and are available in two frame sizes with frame ratings from 800 to 5000 A.

One important LV power circuit breaker rating is its short-time withstand current rating. This rating indicates the level of current that a breaker can handle without damage for a designated short time. This rating is important because an LV power circuit breaker is often required to delay tripping for a short time when a fault current is sensed so that a downstream breaker closer to the fault has time to trip, thereby avoiding a larger system outage.

Frame Size II

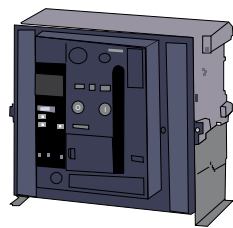

Frame Size III

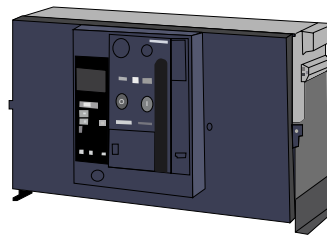

Frame Size II											
Rated Nominal Current	800 A					1600 A					
Rating Class	N	S	H	L	F	N	S	H	L	F	
Interrupting Current ( $I_{cs}$ ) at 254 V	50,000	65,000	85,000	100,000	200,000	50,000	65,000	85,000	100,000	200,000	
Interrupting Current ( $I_{cs}$ ) at 508 V	50,000	65,000	85,000	100,000	200,000	50,000	65,000	85,000	100,000	200,000	
Interrupting Current ( $I_{cs}$ ) at 635 V	50,000	65,000	65,000	85,000	200,000	50,000	65,000	65,000	85,000	200,000	
Short-time Withstand Current ( $I_{cw}$ ) for 0.5 sec	50,000	65,000	65,000	85,000	20,000	50,000	65,000	65,000	85,000	20,000	
Frame Size II											
Rated Nominal Current	2000 A				3200 A						
Rating Class	S	H	L	F	S	H	L				
Interrupting Current ( $I_{cs}$ ) at 254 V	65,000	85,000	100,000	200,000	65,000	85,000	100,000				
Interrupting Current ( $I_{cs}$ ) at 508 V	65,000	85,000	100,000	200,000	65,000	85,000	100,000				
Interrupting Current ( $I_{cs}$ ) at 635 V	65,000	65,000	85,000	200,000	65,000	65,000	85,000				
Short-time Withstand Current ( $I_{cw}$ ) for 0.5 sec	65,000	65,000	85,000	20,000	65,000	65,000	85,000				
Frame Size III											
Rated Nominal Current	3200 A		4000 A			5000 A					
Rating Class	M	F	H	L	M	F	H	L	M	F	
Interrupting Current ( $I_{cs}$ ) at 254 V	150,000	200,000	85,000	100,000	150,000	200,000	85,000	100,000	150,000	200,000	
Interrupting Current ( $I_{cs}$ ) at 508 V	150,000	200,000	85,000	100,000	150,000	200,000	85,000	100,000	150,000	200,000	
Interrupting Current ( $I_{cs}$ ) at 635 V	85,000	200,000	85,000	85,000	85,000	200,000	85,000	85,000	85,000	200,000	
Short-time Withstand Current ( $I_{cw}$ ) for 0.5 sec	100,000 <sup>1</sup>	40,000	85,000	100,000 <sup>1</sup>	100,000 <sup>1</sup>	40,000	85,000	100,000 <sup>1</sup>	100,000 <sup>1</sup>	40,000	

1. Do not apply breaker at 635 V on a system with available fault current greater than 85KA RMS.
2. Interrupting Current and Short-time Withstand Current in Symmetrical RMS Amperes

## WL Electronic Trip Units

Six electronic trip units are available for use with WL circuit breakers. The basic protective functions and communication options available for these trip units are shown in the following diagram. Refer to the SPEEDFAX catalog for additional information regarding trip unit features.

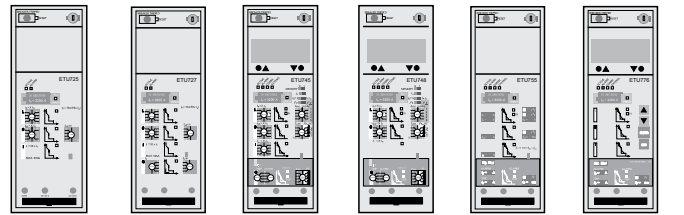

	ETU725	ETU727	ETU745	ETU748	ETU755	ETU776
<b>Basic Protective Functions</b>						
Long time pickup and delay-overload protection (L)	●	●	●	●	●	●
Short circuit protection-short-time delayed (S)	●	●	●	●	●	●
Short-circuit protection-instantaneous (I)	●	●	●	-	●	●
Ground fault protection (G)	-	●	○	○	○	○
<b>Communication</b>						
CubicleBUS	-	-	●	●	●	●
PROFIBUS-DP	-	-	○	○	○	○
MODBUS	-	-	○	○	○	○
Ethernet (BDA)	-	-	○	○	○	○
<b>Additional Features</b>						
LCD display	-	-	○	○	-	●
Dual parameter sets A and B	-	-	-	-	●	●
Metering Function Plus	-	-	○	○	○	○

● = standard, ○ = optional, - = not available

## Review 8

1. Siemens WL circuit breaker family includes insulated case circuit breakers that conform to the UL \_\_\_\_ specification and LV power circuit breakers that conform to the UL \_\_\_\_ specification.
2. WL insulated case circuit breakers are available in both \_\_\_\_- mounted and \_\_\_\_- mounted versions.
3. WL LV power circuit breakers are normally used in switchgear as \_\_\_\_- mounted breakers.
4. WL circuit breakers are available in frame ratings from \_\_\_\_ amps to \_\_\_\_ amps.
5. Ground fault protection is either standard or optional for all WL trip units except \_\_\_\_.

# Review Answers

- Review 1** 1) a; 2) overloads, short circuits; 3) short circuit; 4) overload; 5) sense, measure, act.
- Review 2** 1) contacts; 2) blow-apart; 3) arc chute; 4) over-center; 5) bi-metallic; 6) magnetic.
- Review 3** 1) instantaneous; 2) thermal; 3) 200,000; 4) ampere; 5) overload protection; 6) coordination.
- Review 4** 1) 120, 120/240, 240; 2) 10, 22, 65; 3) one-half inch; 4) QAF, QADH; 5) ground-fault.
- Review 5** 1) 125, smaller; 2) FD; 3) HEG; 4) LMD; 5) CFD6; 6) SLD6, SHLD6.
- Review 6** 1) shunt trip; 2) undervoltage trip; 3) exact alignment; 4) rocker arm assembly; 5) Plug-in.
- Review 7** 1) UL, CSA, NOM, CE; 2) N-Normal, H-High, L-Very High; 3) Model 525; 4) PG; 5) L.
- Review 8** 1) 489, 1066; 2) fixed, drawout; 3) drawout; 4) 800, 5000; 5) ETU725.

# Final Exam

This final exam is intended to be a learning tool. You may use your book during the exam. If you wish to have your test graded, place your answers on the postage-paid response card and mail the card when you are through. If you score 70% or better, we will mail you a course completion certificate.

1. With an increase of current, temperature will \_\_\_\_\_.
  - a. decrease
  - b. increase
  - c. remain the same
  - d. fluctuate
  
2. The amount of current a conductor can carry continuously is known as \_\_\_\_\_.
  - a. ampacity
  - b. instantaneous current
  - c. peak current
  - d. AWG
  
3. Overcurrent protection is covered by *NEC*<sup>®</sup> article \_\_\_\_\_.
  - a. 110
  - b. 430
  - c. 240
  - d. 384
  
4. A \_\_\_\_\_ circuit breaker contact design uses magnetic fields developed around the contacts to help force them apart during an overcurrent condition.
  - a. straight-through
  - b. single-pivot
  - c. dual-pivot
  - d. blow-apart
  
5. Siemens molded case circuit breakers use a/an \_\_\_\_\_ toggle mechanism that is a quick-make and quick-break design.
  - a. over-center
  - b. normally open
  - c. center-off
  - d. normally closed
  
6. The “brain” of the circuit breaker is the \_\_\_\_\_.
  - a. arc chute
  - b. frame
  - c. trip unit
  - d. operating mechanism

7. A/an \_\_\_\_\_ provides both overload and short circuit protection.
- a. instantaneous magnetic-trip-only circuit breaker
  - b. overload relay
  - c. molded case switch
  - d. thermal-magnetic circuit breaker
8. A circuit breaker \_\_\_\_\_ includes all the various component that make up a circuit breaker except the trip unit.
- a. frame
  - b. internal accessory
  - c. external accessory
  - d. ETU
9. The upper-most portion of a circuit breaker time-current curve shows the \_\_\_\_\_ performance of a circuit breaker.
- a. short circuit protection
  - b. instantaneous trip
  - c. continuous current
  - d. current interrupting
10. The application of circuit protective devices in series such that, under overload or fault conditions, only the upstream device nearest the fault will open is known as \_\_\_\_\_.
- a. series-rating
  - b. selective coordination
  - c. instantaneous trip
  - d. current limiting
11. Which of the following Siemens circuit breaker types is an arc fault circuit interrupter?
- a. QP
  - b. QT
  - c. QPF
  - d. QAF
12. Each Siemens \_\_\_\_\_ type circuit breaker provides a 2-pole circuit breaker for 120/240 VAC circuits and two independent 1-pole breakers for 120 VAC circuits.
- a. QT
  - b. QT Duplex
  - c. QT Triplex
  - d. QT Quadplex
13. Which of the following circuit breaker types is not a 125 amp frame circuit breaker?
- a. EB
  - b. EG
  - c. CQD
  - d. NGG

14. Which of the following circuit breaker types has an 800 amp frame size?
- a. FD
  - b. ED
  - c. LMD
  - d. JD
15. True RMS sensing \_\_\_\_\_.
- a. measures peak currents only
  - b. provides a more accurate picture of true heating
  - c. samples current every 1/2 second
  - d. measures peak voltages only
16. Which of the following circuit breaker types has a solid-state trip unit?
- a. HFD6
  - b. SLD6
  - c. ED6
  - d. CFD6
17. An accessory used to allow a circuit breaker to be remotely tripped is called a/an \_\_\_\_\_.
- a. shunt trip
  - b. auxiliary switch
  - c. bell alarm
  - d. handle blocking device
18. Which of the following letter designations is used to indicate that a trip unit provides overload protection?
- a. L
  - b. S
  - c. I
  - d. G
19. Which of the following Siemens VL circuit breaker trip unit models is an electronic trip unit with LCD?
- a. Model 515
  - b. Model 525
  - c. Model 545
  - d. Model 576
20. Siemens WL circuit breakers are available with frame ratings up to \_\_\_\_\_ amps.
- a. 5,000
  - b. 8,000
  - c. 10,000
  - d. 15,000

## quickSTEP Online Courses

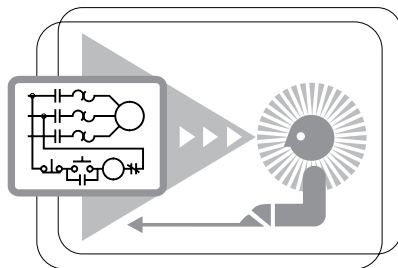

quickSTEP online courses are available at  
<http://www.sea.siemens.com/step>.

The quickSTEP training site is divided into three sections: Courses, Downloads, and a Glossary. Online courses include reviews, a final exam, the ability to print a certificate of completion, and the opportunity to register in the Sales & Distributor training database to maintain a record of your accomplishments.

From this site the complete text of all STEP courses can be downloaded in PDF format. These files contain the most recent changes and updates to the STEP courses.

A unique feature of the quickSTEP site is our pictorial glossary. The pictorial glossary can be accessed from anywhere within a quickSTEP course. This enables the student to look up an unfamiliar word without leaving the current work area.

